

All information in the brochures is general ones, which is not contractual contents.  
Borche reserves the right of any change without prior notice.

# BORCHE



**CT SERVICIO SA | CENTROTECNICA**

C/ de la Llobatona 38  
08840 Viladecans | Barcelona  
T. +34 936 376

[info@centrotecnica.es](mailto:info@centrotecnica.es) | [www.centrotecnica.es](http://www.centrotecnica.es)

Març 2023



## BU-V Two-Platen Series

17 Year's R&D on Two-Platen IMM, Full Range & Big Scale  
Expert of Intelligent Two-Platen IMM

Intelligent Two-platen IMM With PlasCloud App as Standard

PlasCloud makes injection molding more efficient

## The Biggest Two-Platen IMM Manufacturer in Asia

Borche BU6800 is the biggest two platen injection molding machine in Asia in terms of combination of clamping force and injection volume as well as power saving effect. The clamping force reaches to 68000 KN. Machine is with ultra-long daylight and super large mold thickness. Borche BU two platen injection molding machine can be widely applied to aerospace field, automotive industry, transportation field, household appliance, and new rural construction.

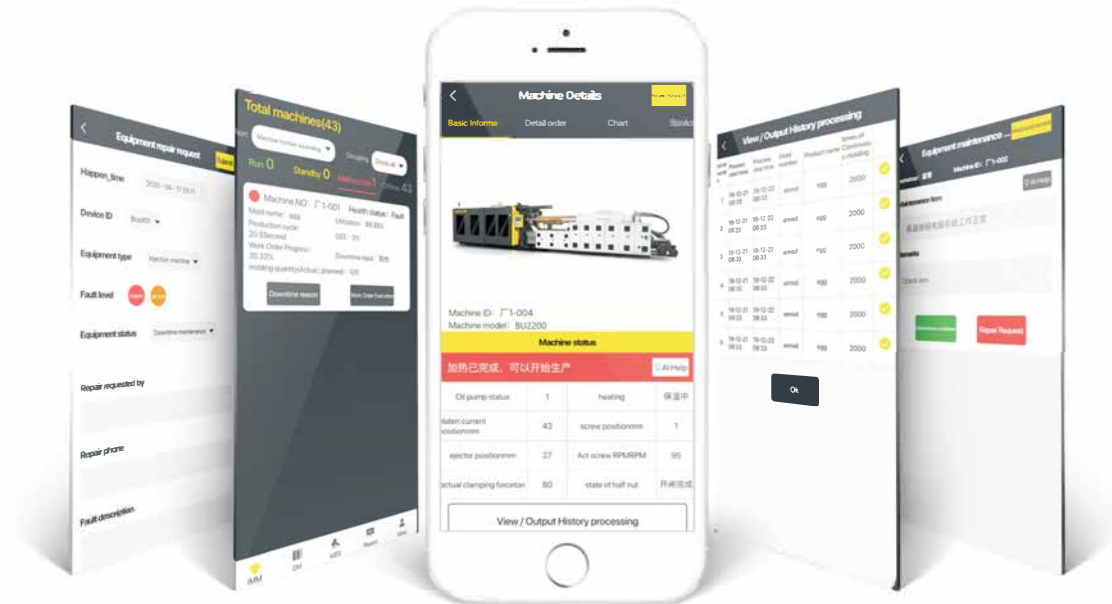

-   
 IoT device
-   
 Process Cloud Management
-   
 Digitalization Maintenance
-   
 Injection Molding Knowledge Bank
-   
 Remote Support



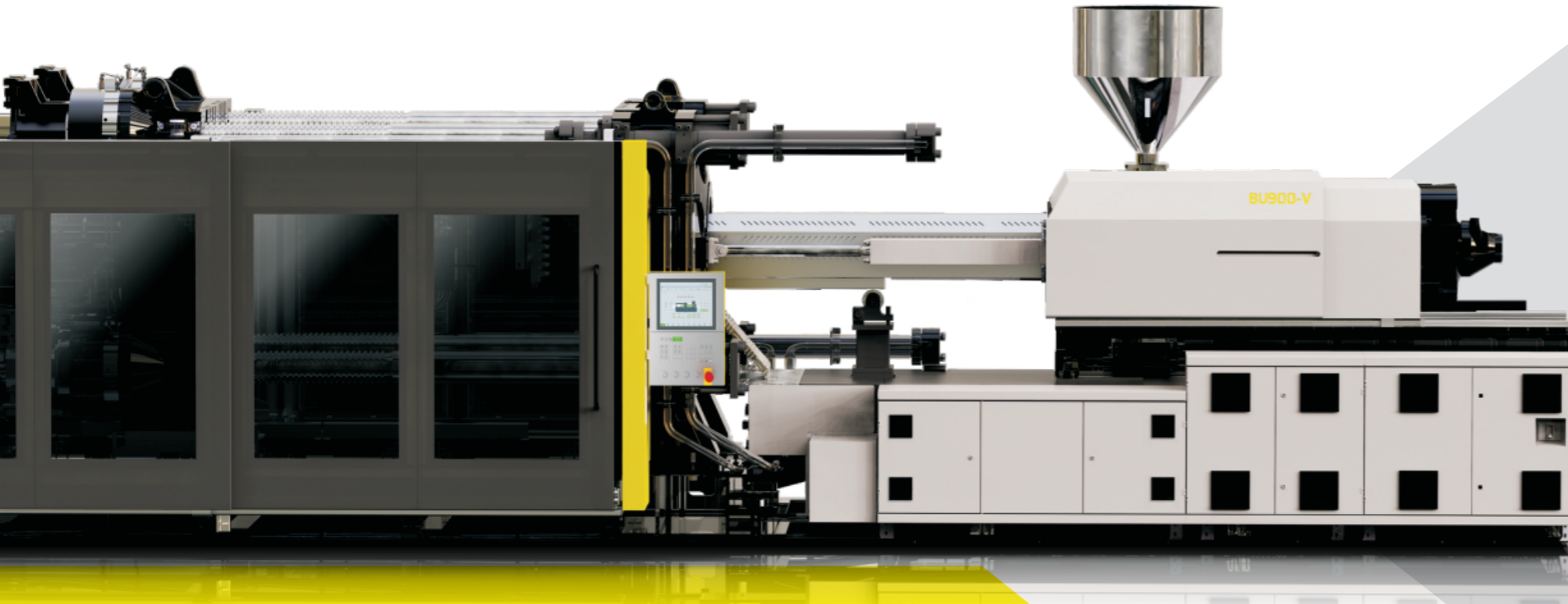

2007, Borche worked with European R&D team to launch two platen IMM, and gained many national patents;  
 2012, Borche new generation two platen IMM was put into production, its technological performance has been in a leading position;  
 2013, Borche BU6800 was launched, which set up the new benchmark in the industry;  
 2017, Borche become the expert of intelligent two platen IMM and the biggest two platen IMM manufacturer in Asia  
 2019 , Second prize of national science and technology progress award

Software name: Borche IMM BU series machine locking program  
 Registered No.: 2012SR135365

Software name: Borche IMM BU series micro-cell machine program  
 Registered No.: 2013SR020689

Software name: Borche IMM BU series oscilloscope program  
 Registered No.: 2013SR049306

Software name: Borche IMM BU series automatic adjusting of mold lock cylinder position program  
 Registered No.: 2013SR160472  
 .....

## Patent

Patent number: ZL201510646437.7  
 Patent name: a mold clamping mechanism, injection molding machine, die-casting molding machine

Patent number: ZL201610509008.X  
 Patent name: a tie-bar locking device and clamping structure

Patent number: ZL201610304376.0  
 Patent Name: a slider subassembly apply to support the moving platen

Patent number: ZL201610937321.3  
 Patent name: a connection structure for fixed platen and tie-bar

Patent number: ZL202110308678.6  
 Patent name: a sectional type of automatic tie-bar removal and mold clamping mechanism for injection molding machine

Patent number: ZL202210487872.X  
 Patent name: a magnetic automatic tie-bar removal of injection molding machine

Patent number: ZL202010609620.0  
 Patent name: a two-platen IMM and a clamping unit control method, device, storage medium

Patent number: ZL202010609659.2  
 Patent name: an adjusting method, device and storage medium for two-platen IMM clamping locking position

Patent number: 201220676060.1  
 Patent name: a copper sleeve structure for mould moving cylinder

Patent number: 201620616379.3  
 Patent name: a support mechanism for lubricating oil self-collection

Patent number: 201620816096.3  
 Patent name: a hydraulic structure with the function of preventing spring mold rebound

Patent number: 201621123964.6  
 Patent name: a supporting plate for moving platen

Patent number: 201621178392.1  
 Patent name: hydraulic power device for servo energy-saving injection molding machine

Patent No. : 201621186756.0  
 Patent name: A hydraulic system of injection molding machine

Patent number: 201621224854.9  
 Patent name: an active oil return and back pressure hydraulic system in plasticizing

Patent number: 201621458962.2  
 Patent name: a liquid cooling system on servo motor of injection molding machine

Patent number: 201720172006.6  
 Patent name: a two - platen type mold locking device

Patent number: 201720171189.X  
 Patent name: a locking subassembly and two - platen type mold locking device

Patent No. : 201720593828.1  
 Patent Name: An electric locking mechanism based on two-platen injection molding machine

Patent No. : 201721734071.X  
 Patent name: synchronous locking mechanism of injection molding machine  
 .....



# Machine Features

## Super Long Lasting Tie Bar

During high pressure locking, four tie bars are under equal force, no inbalanced load occurred, avoiding tie bar broken theoretically.

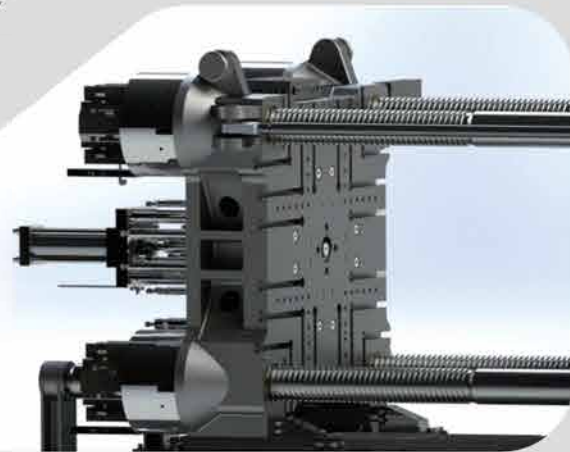

## Moving Platen Clamping

Tie bars move across clamping cylinder, no contact with seals, less leakage risk;  
Module type clamping cylinder, can be assembled and disassembled together, easy for maintenance  
Pistons of four cylinders are controlled separately, which can adjust the locking Position precisely, and assure fast and precise locking.  
Clamping cylinder assembled in the moving platen can balance the load of mold, avoiding forward tilt, improve stability of mold open and clamping movement

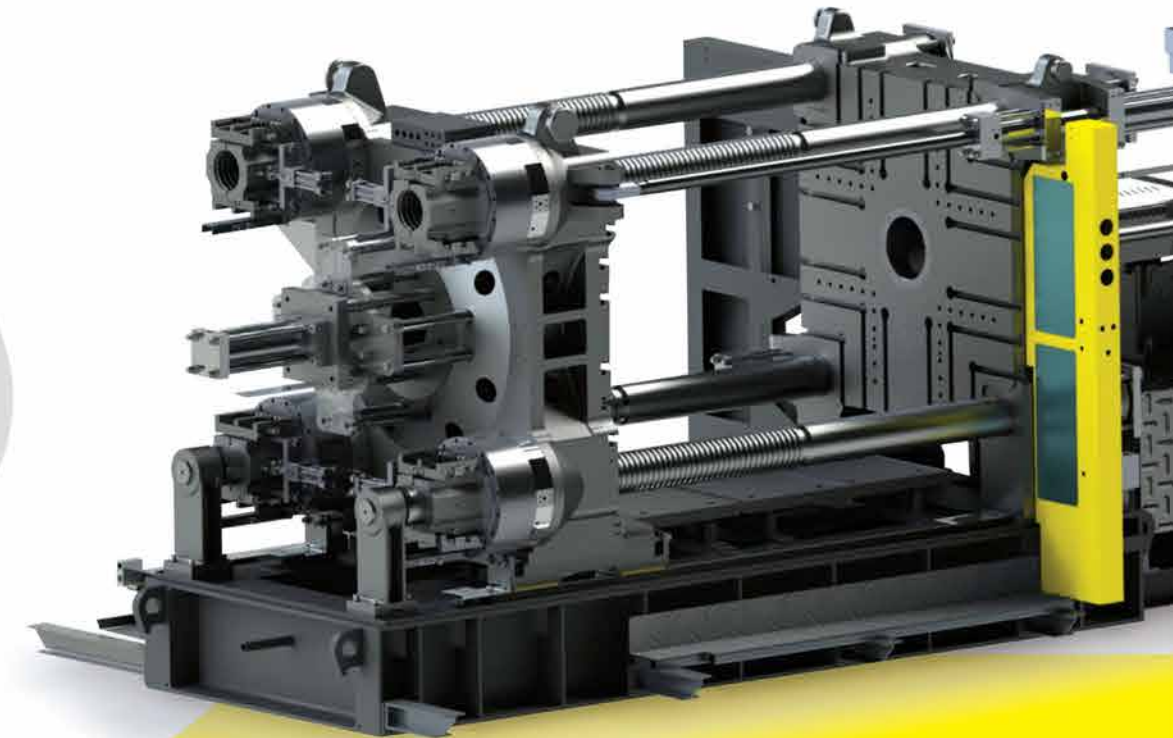

# BORCHE

## Tie Bar Guiding

Borche BU machine adopts the structure of fixing two bottom tie bars, assures platen moving guiding.  
 Machine frame works as the support during platen moving, bottom tie bars work as guiding and auxiliary support.  
 Above new guiding structure can guarantee mold movement stability and reliability, avoiding unbalanced force on tie bars and mold jiggling motion, and can load heavier mold.

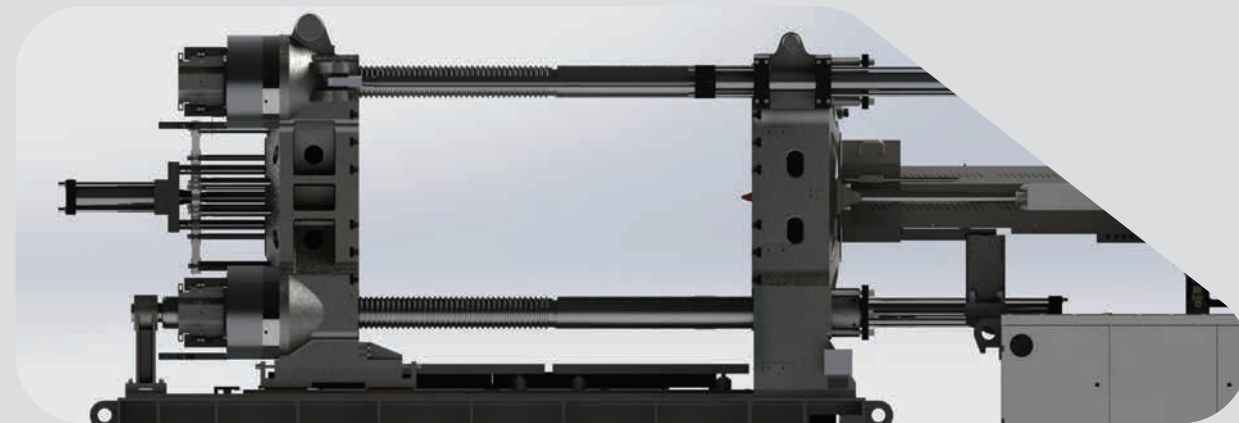

## Shorter Cycle Time

High performance and response controller  
 12" touch screen  
 Intel 1.1G CPU

Better application scalability meets complicated production requirements. With special hydraulic circuit, optimized movement calculation, dry cycle time of the machine is less.



## Innovated Injection Structure

Both carriage cylinder and injection adopt linear guider, which guarantee stable and fast movement. Injection supporting made by one piece casting, is rigid and compact.  
 Double carriage cylinder assures injection unit better centering, and stable movement.

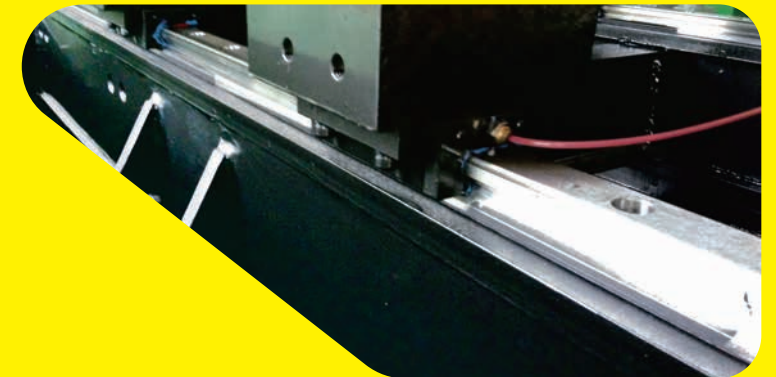

## Intelligent Interconnection

The human-computer interface from IMM enables the Intelligent Interconnection of IMM, peripherals (cooling machine, mold temperature controller etc.), and robot. All equipments are under close loop control and all data is corresponding with each other, thus product quality is improved, and production cost is decreased.



## Municipal Engineering & Environmental Protection Industry

Machine Model: BU4000  
 Molding Technique: Compression Injection Molding  
 Product: Filter Plate  
 Size: 2000mmX2000mmX50mm  
 Weight: 165kg  
 Raw Material: PP+6%GF



Comparison btw use compression molding and not

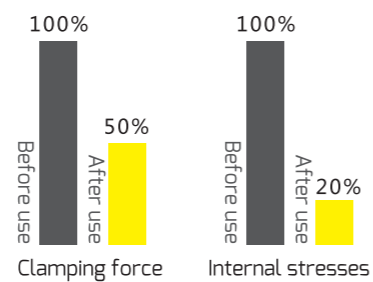

The product is heavy weight and with big projected area, requires precise dimension and small deformation. Low MFI sticky compound needs 8000 ton clamping force to make the products under general molding condition. With compression molding it can be realized with 4000ton.  
 Note: Compression molding is an improved molding method which can increase flow length ratio, allow smaller clamping force, lessen internal stresses, and increase production efficiency.

## Auto Parts

Machine Model: BU3300  
 Molding Technique:  
 Charging during mold open  
 Core out/Ejection forward during mold open  
 Core in/Ejection backward during mold open  
 Product: Bumper  
 Weight: 4.5kg  
 Raw Material: Modified PP



Adopted servo charging, BU3300 realizes three parallel movements, lessen dry cycle time. Cycle can be reduced more if mold cooling time less. Servo valve used for injection increases shot repeatability, meets the high precision and efficiency requirement of auto part molding.



## New Rural Construction Products

Machine Model: BU2500  
 Molding Technique: Enlarge Injection Weight  
 Product: Septic Tank  
 Weight :22.5kg  
 Material: PE

Super large injection unit of Borche BU2500, and equal force of clamping, makes the parts molding easily and efficiently.



## Logistics

Machine Model: BU1800  
 Molding Technique : Deep Cavity products/High pressure mold open  
 Product: 240L trash  
 Weight : 11.5kg  
 Material: PP/PE

Borche BU machine has super large mold opening stroke, and strong opening force, which is perfect to make deep cavity products



## Household Appliance

Machine Model: BU1200  
 Molding Technique: Big Mold Opening Stroke  
 Product: Washing Machine Barrel  
 Weight :3.2kg  
 Material: PP

Thin wall and complicated shape product, needs good plasticizing, high shot speed and stable injection end position. Special designed BU 1200 can meet all the requirements of household appliance industry.

Clamping Unit	Injection Unit														
	2239	3266	4155	5700	7400	11500	13500	17650	29500	40700	51400	64000			
BU500-V		Standard													
BU600-V			Standard												
BU700-V				Standard											
BU800-V				Standard											
BU900-V					Standard										
BU1000-V						Standard									
BU1200-V							Standard								
BU1350-V								Standard							
BU1500-V									Standard						
BU1650-V										Standard					
BU1800-V											Standard				
BU2200-V												Standard			
BU2500-V													Standard		
BU2800-V														Standard	
BU3300-V															Standard

Standard  Optional 

MOLDEL	UNIT	BU500-V			BU600-V			BU700-V			BU800-V			BU900-V			BU1000-V			BU1200-V			BU1350-V					
INTERNATIONAL CLASS NUMBER		3266			4155			5700			5700			7400			7400			11500			13500					
<b>Injection Unit</b>																												
Screw Diameter	mm	70	80	90	80	85	95	90	100	105	90	100	105	100	105	115	100	105	115	105	115	130	115	130	140			
Theoretical Shot Volume	cm <sup>3</sup>	1539	2011	2545	2262	2554	3190	3181	3927	4330	3181	3927	4330	4123	4546	5453	4123	4546	5453	5195	6232	7964	6751	8628	10006			
Theoretical Shot Weight(PS)	g	1401	1830	2316	2058	2324	2903	2895	3574	3940	2895	3574	3940	3752	4137	4962	3752	4137	4962	4728	5671	7247	6144	7851	9105			
Theoretical Shot Weight(PS)	OZ	49	65	82	73	82	102	102	126	139	102	126	139	132	146	175	132	146	175	167	200	256	217	277	321			
Theoretical Injection Pressure	Mpa	212	162	128	184	163	130	181	147	133	181	147	133	180	163	136	180	163	136	221	184	144	200	157	135			
Screw L/D Ratio	L/d	24	21	19	22.3	21	19	25	22.5	21	25	22.5	21	24	23	21	24	23	21	24	22	20	25	22	20.5			
Injection Stroke	mm	400			450			500			500			525			525			600			650					
Screw Rotary Speed Max	rpm	170			168			134			134			115			115			110			105					
Nozzle Contact Force	KN	80			80			200			200			200			200			200			200					
Nozzle Stroke	mm	620			620			675			675			770			770			850			900					
<b>Clamping Unit</b>																												
Theoretical Clamping Force	KN	5000			6000			7000			8000			9000			10000			12000			13500					
Mould Opening Stroke	mm	1335 / 770			1450 / 880			1500 / 950			1600 / 1000			1700 / 1150			1800 / 1200			2000 / 1400			2250 / 1550					
Platen Size,HxV	mm×mm	1210x1180			1310x1310			1500x1350			1550x1450			1670×1540			1740×1515			1920x1820			1990×1890					
Space Between Tine Bars,HxV	mm×mm	860x830			910x910			1060x910			1110x1010			1180×1050			1250×1025			1300x1200			1420×1300					
Daylight Max.	mm	1600			1750			1900			2000			2200			2300			2600			2900					
Mold Thickness(min-max.)	mm	265-830			300-870			400-950			400-1000			500-1050			500-1100			600-1200			650-1350					
Ejector Stroke	mm	250			280			300			300			350			350			380			380					
Theoretical Ejector Force	KN	110			135			210			210			210			210			300			300					
Ejector Pin Hole	unit	4+8+4+1			8+8+4+1			8+8+4+1			8+8+4+1			8+8+1			8+8+1			8+8+8+1			8+8+8+1					
<b>Power Unit</b>																												
System pressure	Mpa	17.5			17.5			17.5			17.5			17.5			17.5			17.5			17.5					
Pump Motor	KW	59(37+22)			67(45+22)			82(60+22)			82(60+22)			97(60+37)			97(60+37)			127(60+45+22)			135(60+45+30)					
Heating Capacity	KW	25			32			41			41			47			47			68			79					
NO.of Heater Zones	unit	6			6			8			8			8			8			8			9					
<b>General Unit</b>																												
Oil Tank Capacity	L	520			600			730			730			960			960			1250			1250					
Machine Dimensions(LxWxH)	m×m×m	7.2x2.35x2.1			7.6x2.35x2.2			8.6x2.87x2.4			8.6x2.87x2.4			9.4x3.2x3.1			9.4x3.2x3.1			10.94x3.32x3.6			11.2x3.5x3.6					
Theoretical Machine Weight	KG	17000			20000			26000			26000			28000			37000			38000			48000			56000		

The specification above is only for reference. Borche reserves the right of change in specification resulting from technical upgrading.





MODEL	UNIT	BU1500-V	BU1650-V	BU1800-V	BU2200-V	BU2500-V	BU2800-V	BU3300-V	BU4000	BU5000	BU6800
INTERNATIONAL CLASS NUMBER		13500	17650	17650	29500	29500	40700	64000	89700	120580	165400

Injection Unit		A	B	C	A	B	C	A	B	C	A	B	C	A	B	C	A	B	C	A	A	A	A
Screw Diameter	mm	115	130	140	130	140	150	130	140	150	150	160	170	150	160	170	165	185	205	215	240	270	300
Theoretical Shot Volume	cm <sup>3</sup>	6751	8628	10006	9291	10776	12370	9291	10776	12370	16611	18900	21336	16611	18900	21336	19779	24864	30531	45744	56773	77295	110270
Theoretical Shot Weight(PS)	g	6144	7851	9105	8455	9806	11257	8455	9806	11257	15116	17199	19416	15116	17199	19416	17999	22626	27783	41627	51663	70338	100346
Theoretical Shot Weight(PS)	OZ	217	277	321	298	346	397	298	346	397	533	607	685	533	607	685	635	798	980	1468	1822	2481	3540
Theoretical Injection Pressure	Mpa	200	157	135	191	164	143	191	164	143	178	156	139	178	156	139	207	165	134	140	158	158	150
Screw L/D Ratio	L/d	25	22	20.5	24	22	21	24	22	21	23	21.6	20	23	21.6	20	26	23	21	21	22	22	22
Injection Stroke	mm		650			700			700			940			940			925		1260	1255	1350	1560
Screw Rotary Speed Max	rpm		105			102			102			87			87			72		60	40	50	30
Nozzle Contact Force	KN		200			200			200			290			290			290		290	480	480	640
Nozzle Stroke	mm		900			965			965			1110			1110			1110		1110	1200	1200	1400
<b>Clamping Unit</b>																							
Theoretical Clamping Force	KN		15000			16500			18000			22000			25000			28000		33000	40000	50000	68000
Mould Opening Stroke	mm		2400 / 1700			2500 / 1700			2500 / 1700			2800 / 1900			2800 / 1900			3100 / 2100		3160 / 2160	3370 / 2260	3600 / 2500	3800 / 2700
Platen Size,HxV	mm×mm		2120×2120			2215×2115			2400×2240			2620×2370			2740×2540			2840×2640		3060×2800	3440×3040	3700×3280	3800×3680
Space Between Tine Bars,HxV	mm×mm		1480×1480			1580×1480			1650×1550			1850×1600			1950×1750			2000×1800		2160×1900	2420×2020	2560×2160	2600×2450
Daylight Max.	mm		3100			3200			3200			3600			3600			4000		4160	4370	4800	5000
Mold Thickness(min-	mm		700-1400			700-1500			700-1500			800-1700			800-1700			900-1900		1000-2000	1000-2110	1200-2300	1200-2300
Ejector Stroke	mm		380			380			380			450			450			550		550	550	800	800
Theoretical Ejector Force	KN		300			300			300			390			390			550		550	550	1200	1200
Ejector Pin Hole	unit		8+8+8+1			8+8+8+1			8+8+8+1			8+8+8+1			8+8+8+1			8+8+8+8+1		8+8+8+8+1	8+8+8+8+1	8+8+8+4+1	8+8+8+4+1
<b>Power Unit</b>																							
System pressure	Mpa		17.5			17.5			17.5			17.5			17.5			17.5		17.5	17.5	17.5	17.5
Pump Motor	KW		135(60+45+30)			165(60x2+45)			165(60x2+45)			180(60+60+60)			180(60+60+60)			199(94+60+45)		233(94x2+45)	327(94x3+45)	376(94x4)	450(45x10)
Heating Capacity	KW		79			81			81			97			97			176		186	269	288	328
NO.of Heater Zones	unit		9			9			9			9			9			15		15	15	15	15
<b>General Unit</b>																							
Oil Tank Capacity	L		1250			1550			1550			1750			1750			2880		2880	4400	5000	6300
Machine Dimensions(LxWxH)	m×m×m		11.28x3.5x3.6			12.35x3.6x3.6			12.35x3.8x3.6			14.5x4.43x3.8			14.6x4.43x3.9			16.35x4.77x3.9		17.5x4.72x4.1	20.1x5.1x4.5	23.5x5.5x5.1	25x6.1x5.8
Theoretical Machine Weight	KG		61000			70000			81000			108000			118000			142000		166000	240000	345000	500000

The specification above is only for reference. Borche reserves the right of change in specification resulting from technical upgrading.



MOLDEL	BU500-V									BU600-V							BU700-V							BU800-V																					
INTERNATIONAL CLASS NO.	2239			3266			4155			2239			3266			4155			5700			3266			4155			5700			7400														
<b>Injection Unit</b>																																													
Screw Diameter	60	70	80	<b>70</b>	<b>80</b>	<b>90</b>	80	85	95	60	70	80	70	80	90	<b>80</b>	<b>85</b>	<b>95</b>	90	100	105	70	80	90	80	85	95	<b>90</b>	<b>100</b>	<b>105</b>	100	105	115	70	80	90	80	85	95	<b>90</b>	<b>100</b>	<b>105</b>	100	105	115
Shot Volume	990	1347	1759	<b>1539</b>	<b>2011</b>	<b>2545</b>	2262	2554	3190	990	1347	1759	1539	2011	2545	<b>2262</b>	<b>2554</b>	<b>3190</b>	3181	3927	4330	1539	2011	2545	2262	2554	3190	<b>3181</b>	<b>3927</b>	<b>4330</b>	4123	4546	5453	1539	2011	2545	2262	2554	3190	<b>3181</b>	<b>3927</b>	<b>4330</b>	4123	4546	5453
Shot Weight(PS)	901	1226	1601	<b>1401</b>	<b>1830</b>	<b>2316</b>	2058	2324	2903	901	1226	1601	1401	1830	2316	<b>2058</b>	<b>2324</b>	<b>2903</b>	2895	3574	3940	1401	1830	2316	2058	2324	2903	<b>2895</b>	<b>3574</b>	<b>3940</b>	3752	4137	4962	1401	1830	2316	2058	2324	2903	<b>2895</b>	<b>3574</b>	<b>3940</b>	3752	4137	4962
Shot Weight(PS)	32	43	56	<b>49</b>	<b>65</b>	<b>82</b>	73	82	102	32	43	56	49	65	82	<b>73</b>	<b>82</b>	<b>102</b>	102	126	139	49	65	82	73	82	102	<b>102</b>	<b>126</b>	<b>139</b>	132	146	175	49	65	82	73	82	102	<b>102</b>	<b>126</b>	<b>139</b>	132	146	175
Injection Pressure	226	166	127	<b>212</b>	<b>162</b>	<b>128</b>	184	163	130	226	166	127	212	162	128	<b>184</b>	<b>163</b>	<b>130</b>	181	147	133	212	162	128	184	163	130	<b>181</b>	<b>147</b>	<b>133</b>	180	163	136	212	162	128	184	163	130	<b>181</b>	<b>147</b>	<b>133</b>	180	163	136
Screw L/D Ratio	24.5	21	18.5	<b>24</b>	<b>21</b>	<b>19</b>	22.3	21	19	24.5	21	18.5	24	21	19	<b>22.3</b>	<b>21</b>	<b>19</b>	25	22.5	21	24	21	19	22.3	21	19	<b>25</b>	<b>22.5</b>	<b>21</b>	24	23	21	24	21	19	22.3	21	19	<b>25</b>	<b>22.5</b>	<b>21</b>	24	23	21
Injection Stroke	350			400			450			350			400			450			500			400			450			500			525			400			450			500			525		
Screw Rotary Speed Max	210			170			168			210			170			168			134			170			168			134			115			199			168			134			115		
Nozzle Contact Force	70			80			80			70			80			80			200			80			80			200			200			80			80			200			200		
Nozzle Stroke	620			620			620			620			620			620			675			620			620			675			770			620			620			675			770		
<b>Clamping Unit</b>																																													
Clamping Force	5000									6000							7000							8000																					
Mould Opening Stroke	1335 / 770									1450 / 880							1500 / 950							1600 / 1000																					
Platen Size,HxV	1210x1180									1310x1310							1500x1350							1550x1450																					
Space Between Tie Bars,HxV	860x830									910x910							1060x910							1110x1010																					
Daylight Max.	1600									1750							1900							2000																					
Mold Thickness(min-max)	265-830									300-870							400-950							400-1000																					
Ejector Stroke	250									280							300							300																					
Ejector Force	110									135							210							210																					
Ejector Pin Hole	4+8+4+1									8+8+4+1							8+8+4+1							8+8+4+1																					
<b>Power Unit</b>																																													
System pressure	17.5			17.5			17.5			17.5			17.5			17.5			17.5			17.5			17.5			17.5			17.5			17.5			17.5			17.5					
Pump Motor	52(30+22)			59(37+22)			67(45+22)			52(30+22)			59(37+22)			67(45+22)			82(60+22)			59(37+22)			67(45+22)			82(60+22)			97(60+37)			67(45+22)			67(45+22)			82(60+22)			97(60+37)		
Heating Capacity	18.5			25			32			18.5			25			32			41			25			32			41			47			25			32			41			47		
NO.of Heater Zones	6			6			6			6			6			6			8			6			6			8			8			6			6			8			8		
<b>General Unit</b>																																													
Oil Tank Capacity	520			520			600			520			520			600			730			520			600			730			960			520			600			730			960		
Machine Dimensions(LxWxH)	7.2x2.35x2.1			7.2x2.35x2.1			7.3x2.35x2.1			7.5x2.35x2.2			7.5x2.35x2.2			7.6x2.35x2.2			8.26x2.35x2.2			7.85x2.87x2.4			7.94x2.87x2.4			8.6x2.87x2.4			8.97x2.87x2.4			7.85x2.87x2.4			7.94x2.87x2.4			8.6x2.87x2.4			8.97x2.87x2.4		
Machine Weight	16500			17000			17500			19000			20000			20000			22000			24000			24000			26000			28000			26000			26000			28000			30000		

The specification above is only for reference. Borche reserves the right of change in specification resulting from technical upgrading.



MODEL	UNIT	BU900-V				BU1000-V				BU1200-V				BU1350-V			
		4155	5700	7400	11500	4155	5700	7400	11500	5700	7400	11500	13500	7400	11500	13500	17650
<b>Injection Unit</b>																	
Screw Diameter	mm	80 85 95	90 100 105	<b>100 105 115</b>	105 115 130	80 85 95	90 100 105	<b>100 105 115</b>	105 115 130	90 100 105	100 105 115	<b>105 115 130</b>	115 130 140	100 105 115	105 115 130	<b>115 130 140</b>	130 140 150
Shot Volume	cm <sup>3</sup>	2262 2554 3190	3181 3927 4330	<b>4123 4546 5453</b>	5195 6232 7964	2262 2554 3190	3181 3927 4330	<b>4123 4546 5453</b>	5195 6232 7964	3181 3927 4330	4123 4546 5453	<b>5195 6232 7964</b>	6751 8628 10006	4123 4546 5453	5195 6232 7964	<b>6751 8628 10006</b>	9291 10776 12370
Shot Weight(PS)	g	2058 2324 2903	2895 3574 3940	<b>3752 4137 4962</b>	4728 5671 7247	2058 2324 2903	2895 3574 3940	<b>3752 4137 4962</b>	4728 5671 7247	2895 3574 3940	3752 4137 4962	<b>4728 5671 7247</b>	6144 7851 9105	3752 4137 4962	4728 5671 7247	<b>6144 7851 9105</b>	8455 9806 11257
Shot Weight(PS)	OZ	73 82 102	102 126 139	<b>132 146 175</b>	167 200 256	73 82 102	102 126 139	<b>132 146 175</b>	167 200 256	102 126 139	132 146 175	<b>167 200 256</b>	217 277 321	132 146 175	167 200 256	<b>217 277 321</b>	298 346 397
Injection Pressure	Mpa	184 163 130	181 147 133	<b>180 163 136</b>	221 184 144	184 163 130	181 147 133	<b>180 163 136</b>	221 184 144	181 147 133	180 163 136	<b>221 184 144</b>	200 157 135	180 163 136	221 184 144	<b>200 157 135</b>	191 164 143
Screw L/D Ratio	L/d	22.3 21 19	25 22.5 21	<b>24 23 21</b>	24 22 20	22.3 21 19	25 22.5 21	<b>24 23 21</b>	24 22 20	25 22.5 21	24 23 21	<b>24 22 20</b>	25 22 20.5	24 23 21	24 22 20	<b>25 22 20.5</b>	24 22 21
Injection Stroke	mm	450	500	525	600	450	500	525	600	500	525	600	650	525	600	650	700
Screw Rotary Speed Max	rpm	168	134	115	110	168	134	115	110	134	115	110	105	115	110	105	102
Nozzle Contact Force	KN	80	200	200	200	80	200	200	200	200	200	200	200	200	200	200	200
Nozzle Stroke	mm	620	675	770	850	620	675	770	850	675	770	850	900	770	850	900	965
<b>Clamping Unit</b>																	
Clamping Force	KN	9000				10000				12000				13500			
Mould Opening Stroke	mm	1700 / 1150				1800 / 1200				2000 / 1400				2250 / 1550			
Platen Size,HxV	mm×mm	1670×1540				1740×1515				1920×1820				1990×1890			
Space Between Tie Bars,HxV	mm×mm	1180×1050				1250×1025				1300×1200				1420×1300			
Daylight Max.	mm	2200				2300				2600				2900			
Mold Thickness(min-max)	mm	500-1050				500-1100				600-1200				650-1350			
Ejector Stroke	mm	350				350				380				380			
Ejector Force	KN	210				210				300				300			
Ejector Pin Hole	unit	8+8+1				8+8+1				8+8+8+1				8+8+8+1			
<b>Power Unit</b>																	
System pressure	Mpa	17.5	17.5	17.5	17.5	17.5	17.5	17.5	17.5	17.5	17.5	17.5	17.5	17.5	17.5	17.5	17.5
Pump Motor	kW	75(45+30)	82(60+22)	97(60+37)	127(60+45+22)	82(60+22)	82(60+22)	97(60+37)	127(60+45+22)	82(60+22)	97(60+37)	127(60+45+22)	135(60+45+30)	105(60+45)	127(60+45+22)	135(60+45+30)	165(60x2+45)
Heating Capacity	kw	32	41	47	68	32	41	47	68	41	47	68	79	47	68	79	81
NO.of Heater Zones	unit	6	8	8	9	6	8	8	9	8	8	9	9	8	9	9	9
<b>General Unit</b>																	
Oil Tank Capacity	L	600	730	960	1250	600	730	960	1250	730	960	1250	1250	960	1250	1250	1550
Machine Dimensions(LxWxH)	m×m×m	8.35x3.2x3.1	9.01x3.2x3.1	9.4x3.2x3.1	10.22x3.2x3.1	8.35x3.2x3.1	9.01x3.2x3.1	9.4x3.2x3.1	10.22x3.2x3.1	9.74x3.32x3.6	10.11x3.32x3.6	10.94x3.32x3.6	10.97x3.32x3.6	10.27x3.5x3.6	11.1x3.5x3.6	11.2x3.5x3.6	11.91x3.5x3.6
Machine Weight	KG	33000	35000	37000	39000	34000	36000	38000	40000	44000	46000	48000	50000	52000	54000	56000	58000

The specification above is only for reference. Borche reserves the right of change in specification resulting from technical upgrading.

MODEL	UNIT	BU1500-V				BU1650-V				BU1800-V				BU2200-V																										
		7400		11500		13500		17650		11500		13500		17650		29500		11500		13500		17650		29500		40700														
<b>Injection Unit</b>																																								
Screw Diameter	mm	100	105	115	105	115	130	<b>115</b>	<b>130</b>	<b>140</b>	130	140	150	105	115	130	115	130	140	<b>130</b>	<b>140</b>	<b>150</b>	150	160	170	105	115	130	115	130	140	130	140	150	<b>150</b>	<b>160</b>	<b>170</b>	165	185	205
Shot Volume	cm <sup>3</sup>	4123	4546	5453	5195	6232	7964	<b>6751</b>	<b>8628</b>	<b>10006</b>	9291	10776	12370	5195	6232	7964	6751	8628	10006	<b>9291</b>	<b>10776</b>	<b>12370</b>	16611	18900	21336	5195	6232	7964	6751	8628	10006	9291	10776	12370	<b>16611</b>	<b>18900</b>	<b>21336</b>	19779	24864	30531
Shot Weight(PS)	g	3752	4137	4962	4728	5671	7247	<b>6144</b>	<b>7851</b>	<b>9105</b>	8455	9806	11257	4728	5671	7247	6144	7851	9105	<b>8455</b>	<b>9806</b>	<b>11257</b>	15116	17199	19416	4728	5671	7247	6144	7851	9105	8455	9806	11257	<b>15116</b>	<b>17199</b>	<b>19416</b>	17999	22626	27783
Shot Weight(PS)	OZ	132	146	175	167	200	256	<b>217</b>	<b>277</b>	<b>321</b>	298	346	397	167	200	256	217	277	321	<b>298</b>	<b>346</b>	<b>397</b>	533	607	685	167	200	256	217	277	321	298	346	397	<b>533</b>	<b>607</b>	<b>685</b>	635	798	980
Injection Pressure	Mpa	180	163	136	221	184	144	<b>200</b>	<b>157</b>	<b>135</b>	191	164	143	221	184	144	200	157	135	<b>191</b>	<b>164</b>	<b>143</b>	178	156	139	221	184	144	200	157	135	191	164	143	<b>178</b>	<b>156</b>	<b>139</b>	207	165	134
Screw L/D Ratio	L/d	24	23	21	24	22	20	<b>25</b>	<b>22</b>	<b>20.5</b>	24	22	21	24	22	20	25	22	20.5	<b>24</b>	<b>22</b>	<b>21</b>	23	21.6	20	24	22	20	25	22	20.5	24	22	21	<b>23</b>	<b>21.6</b>	<b>20</b>	26	23	21
Injection Stroke	mm	525		600		650		700		600		650		700		940		600		650		700		940		600		650		700		940		925						
Screw Rotary Speed Max	rpm	115		110		105		102		110		105		102		82		110		102		102		85		110		120		102		85		72						
Nozzle Contact Force	KN	200		200		200		200		200		200		290		200		200		200		290		200		200		200		290		290								
Nozzle Stroke	mm	770		850		900		965		850		900		965		1110		850		900		965		1110		900		900		965		1110								
<b>Clamping Unit</b>																																								
Clamping Force	KN	15000				16500				18000				22000																										
Mould Opening Stroke	mm	2400 / 1700				2500 / 1700				2500 / 1700				2800 / 1900																										
Platen Size,HxV	mm×mm	2120×2120				2215×2115				2400×2240				2620×2370																										
Space Between Tie Bars,HxV	mm×mm	1480×1480				1580×1480				1650×1550				1850×1600																										
Daylight Max.	mm	3100				3200				3200				3600																										
Mold Thickness(min-max)	mm	700-1400				700-1500				700-1500				800-1700																										
Ejector Stroke	mm	380				380				380				450																										
Ejector Force	KN	300				300				300				390																										
Ejector Pin Hole	unit	8+8+8+1				8+8+8+1				8+8+8+1				8+8+8+1																										
<b>Power Unit</b>																																								
System pressure	Mpa	17.5		17.5		17.5		17.5		17.5		17.5		17.5		17.5		17.5		17.5		17.5		17.5		17.5		17.5		17.5		17.5								
Pump Motor	kW	105(60+45)		127(60+45+22)		135(60+45+30)		165(60x2+45)		135(60+45+30)		135(60+45+30)		165(60x2+45)		165(60x2+45)		135(60+45+30)		135(60+45+30)		165(60x2+45)		180(60+60+60)		165(60x2+45)		165(60x2+45)		165(60x2+45)		180(60+60+60)		199(94+60+45)						
Heating Capacity	kw	47		68		79		81		68		79		81		97		68		79		81		97		68		79		81		97		176						
NO.of Heater Zones	unit	8		9		9		9		9		9		9		9		9		9		9		9		9		9		9		15								
<b>General Unit</b>																																								
Oil Tank Capacity	L	960		1250		1250		1550		1250		1250		1550		1750		1250		1250		1550		1750		1250		1250		1550		1750		2880						
Machine Dimensions(LxWxH)	m×m×m	10.41x3.5x3.6		11.24x3.5x3.6		11.28x3.5x3.6		11.97x3.5x3.6		11.62x3.6x3.6		11.66x3.6x3.6		12.35x3.6x3.6		13.71x3.6x3.6		11.62x3.8x3.6		11.66x3.8x3.6		12.35x3.8x3.6		13.71x3.8x3.6		12.38x4.43x3.8		12.42x4.43x3.8		13.11x4.43x3.8		14.5x4.43x3.8		15.5x4.43x3.8						
Machine Weight	KG	57000		59000		61000		63000		66000		68000		70000		78000		77000		79000		81000		89000		96000		98000		100000		108000		116000						

The specification above is only for reference. Borche reserves the right of change in specification resulting from technical upgrading.



MODEL	UNIT	BU2500-V									BU2800-V						BU3300-V																							
		17650			29500			40700			17650			29500			40700			51400			64000			17650			29500			40700			51400			64000		
<b>Injection Unit</b>																																								
Screw Diameter	mm	130	140	150	<b>150</b>	<b>160</b>	<b>170</b>	165	185	205	130	140	150	150	160	170	<b>165</b>	<b>185</b>	<b>205</b>	205	215	130	140	150	150	160	170	165	185	205	205	<b>215</b>								
Shot Volume	cm <sup>3</sup>	9291	10776	12370	<b>16611</b>	<b>18900</b>	<b>21336</b>	19779	24864	30531	9291	10776	12370	16611	18900	21336	<b>19779</b>	<b>24864</b>	<b>30531</b>	38287	45744	9291	10776	12370	16611	18900	21336	19779	24864	30531	38287	<b>45744</b>								
Shot Weight(PS)	g	8455	9806	11257	<b>15116</b>	<b>17199</b>	<b>19416</b>	17999	22626	27783	8455	9806	11257	15116	17199	19416	<b>17999</b>	<b>22626</b>	<b>27783</b>	34482	41627	8455	9806	11257	15116	17199	19416	17999	22626	27783	34482	<b>41627</b>								
Shot Weight(PS)	OZ	298	346	397	<b>533</b>	<b>607</b>	<b>685</b>	635	798	980	298	346	397	533	607	685	<b>635</b>	<b>798</b>	<b>980</b>	1229	1468	298	346	397	533	607	685	635	798	980	1229	<b>1468</b>								
Injection Pressure	Mpa	191	164	143	<b>178</b>	<b>156</b>	<b>139</b>	207	165	134	191	164	143	178	156	139	<b>207</b>	<b>165</b>	<b>134</b>	134	140	191	164	143	178	156	139	207	165	134	134	<b>140</b>								
Screw L/D Ratio	L/d	24	22	21	<b>23</b>	<b>21.6</b>	<b>20</b>	26	23	21	24	22	21	23	21.6	20	<b>26</b>	<b>23</b>	<b>21</b>	21	21	24	22	21	23	21.6	20	26	23	21	21	<b>21</b>								
Injection Stroke	mm	700			940			925			700			940			925			1160			1260			700			940			925			1160			1260		
Screw Rotary Speed Max	rpm	110			85			72			114			85			72			72			60			114			85			72			72			60		
Nozzle Contact Force	KN	200			290			290			200			290			290			290			290			200			290			290			290			290		
Nozzle Stroke	mm	965			1110			1110			965			1100			1110			1110			1110			965			1100			1110			1110			1110		
<b>Clamping Unit</b>																																								
Clamping Force	KN	25000									28000									33000																				
Mould Opening Stroke	mm	2800 / 1900									3100 / 2100									3160 / 2160																				
Platen Size,HxV	mm×mm	2740x2540									2840x2640									3060×2800																				
Space Between Tie Bars,HxV	mm×mm	1950x1750									2000x1800									2160×1900																				
Daylight Max.	mm	3600									4000									4160																				
Mold Thickness(min-max)	mm	800-1700									900-1900									1000-2000																				
Ejector Stroke	mm	450									550									550																				
Ejector Force	KN	390									550									550																				
Ejector Pin Hole	unit	8+8+8+1									8+8+8+8+1									8+8+8+8+1																				
<b>Power Unit</b>																																								
System pressure	Mpa	17.5			17.5			17.5			17.5			17.5			17.5			17.5			17.5			17.5			17.5			17.5			17.5			17.5		
Pump Motor	kW	176(94+60+22)			180(60+60+60)			199(94+60+45)			184(94+60+30)			180(60+60+60)			199(94+60+45)			214(60x2+94)			233(94x2+45)			184(94+60+30)			180(60+60+60)			199(94+60+45)			214(60x2+94)			233(94x2+45)		
Heating Capacity	kw	81			97			176			81			97			176			176			186			81			97			176			176			186		
NO.of Heater Zones	unit	9			9			15			9			9			15			15			15			9			9			15			15			15		
<b>General Unit</b>																																								
Oil Tank Capacity	L	1550			1750			2880			1550			1750			2880			2880			2880			1550			1750			2880			2880			2880		
Machine Dimensions(LxWxH)	m×m×m	13.22x4.43x3.9			14.6x4.43x3.9			15.6x4.43x3.9			14.0x4.77x3.9			15.35x4.77x3.9			16.35x4.77x3.9			16.35x4.77x3.9			17.2x4.77x3.9			14.29x4.72x4.1			15.65x4.72x4.1			16.65x4.72x4.1			16.65x4.72x4.1			17.5x4.72x4.1		
Machine Weight	KG	110000			118000			126000			126000			134000			142000			142000			146000			146000			154000			162000			162000			166000		

The specification above is only for reference. Borche reserves the right of change in specification resulting from technical upgrading.



## DESCRIPTION

MOLDEL	UNIT	BU500-V		
INTERNATIONAL CLASS NO.		2239	3266	4155
<b>Injection Unit</b>				
Screw Diameter	mm	60 70 80 <b>70</b> <b>80</b> <b>90</b> 80 85 95		
Shot Volume	cm <sup>3</sup>	990 1347 1759 <b>1539</b> <b>2011</b> <b>2545</b> 2262 2554 3190		
Shot Weight(PS)	g	901 1226 1601 <b>1401</b> <b>1830</b> <b>2316</b> 2058 2324 2903		
Shot Weight(PS)	OZ	32 43 56 <b>49</b> <b>65</b> <b>82</b> 73 82 102		
Injection Pressure	Mpa	226 166 127 <b>212</b> <b>162</b> <b>128</b> 184 163 130		
Screw L/D Ratio	L/d	24.5 21 18.5 <b>24</b> <b>21</b> <b>19</b> 22.3 21 19		
Injection Stroke	mm	350 400 450		
Screw Rotary Speed Max	rpm	210 170 168		
Nozzle Contact Force	KN	70 80 80		
Nozzle Stroke	mm	620 620 620		
<b>Clamping Unit</b>				
Clamping Force	KN	5000		
Mould Opening Stroke	mm	1335 / 770		
Platen Size,HxW	mm×mm	1210x1180		
Space Between Tie Bars,HxW	mm×mm	860x830		
Daylight Max	mm	1600		
Mold Thickness (min-max)	mm	265-830		
Ejector Stroke	mm	250		
Ejector Force	KN	110		
Ejector Pin Hole	unit	4+8+4+1		
<b>Power Unit</b>				
System pressure	Mpa	17.5	17.5	17.5
Pump Motor	kW	52(30+22)	59(37+22)	67(45+22)
Heating Capacity	kw	18.5	25	32
NO of Heater Zones	unit	6	6	6
<b>General Unit</b>				
Oil Tank Capacity	L	520	520	600
Machine Dimensions (LxWxH)	m×m×m	7.2x2.35x2.1	7.2x2.35x2.1	7.3x2.35x2.1
Machine Weight	KG	16500	17000	17500

## Appearance and Installation Dimensions

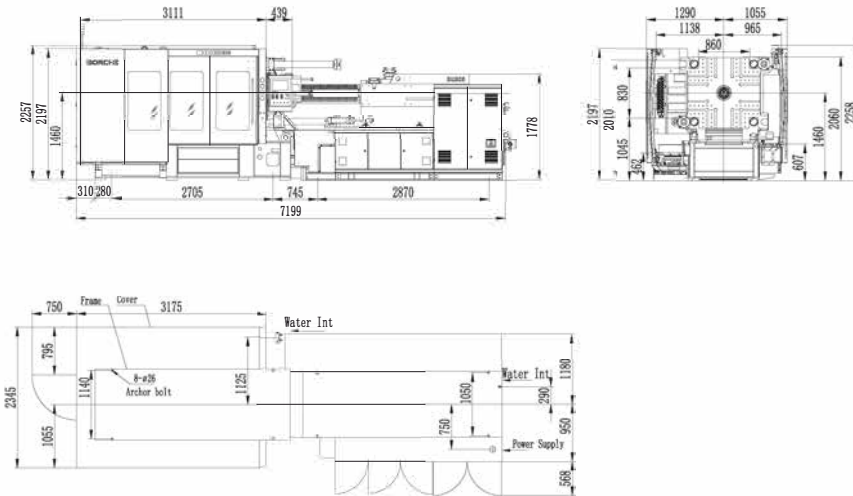

## Mold Platen Drawing

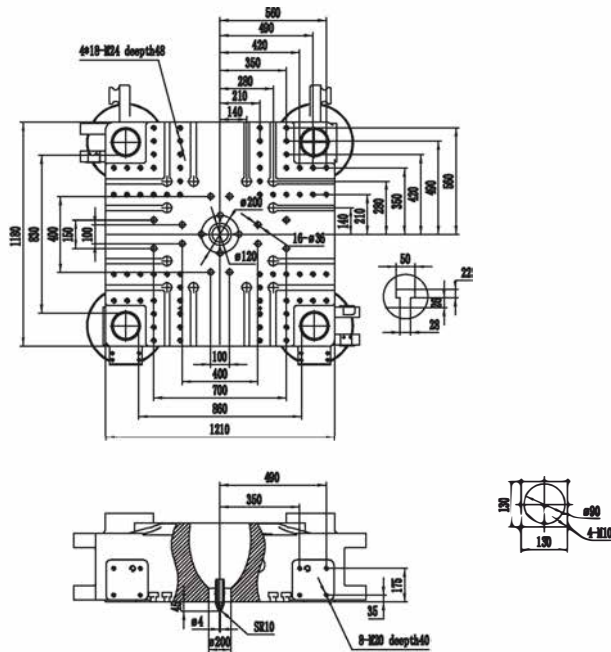

## DESCRIPTION

MOLDEL	UNIT	BU600-V			
INTERNATIONAL CLASS NO.		2239	3266	4155	5700
<b>Injection Unit</b>					
Screw Diameter	mm	60 70 80 70 80 90 <b>80</b> <b>85</b> <b>95</b> 90 100 105			
Shot Volume	cm <sup>3</sup>	990 1347 1759 1539 2011 2545 <b>2262</b> <b>2554</b> <b>3190</b> 3181 3927 4330			
Shot Weight(PS)	g	901 1226 1601 1401 1830 2316 <b>2058</b> <b>2324</b> <b>2903</b> 2895 3574 3940			
Shot Weight(PS)	OZ	32 43 56 49 65 82 <b>73</b> <b>82</b> <b>102</b> 102 126 139			
Injection Pressure	Mpa	226 166 127 212 162 128 <b>184</b> <b>163</b> <b>130</b> 181 147 133			
Screw L/D Ratio	L/d	24.5 21 18.5 24 21 19 <b>22.3</b> <b>21</b> <b>19</b> 25 22.5 21			
Injection Stroke	mm	350 400 450 500			
Screw Rotary Speed Max	rpm	210 170 168 134			
Nozzle Contact Force	KN	70 80 80 200			
Nozzle Stroke	mm	620 620 620 675			
<b>Clamping Unit</b>					
Clamping Force	KN	6000			
Mould Opening Stroke	mm	1450 / 880			
Platen Size,HxW	mm×mm	1310x1310			
Space Between Tie Bars,HxW	mm×mm	910x910			
Daylight Max	mm	1750			
Mold Thickness (min-max)	mm	300-870			
Ejector Stroke	mm	280			
Ejector Force	KN	135			
Ejector Pin Hole	unit	8+8+4+1			
<b>Power Unit</b>					
System pressure	Mpa	17.5	17.5	17.5	17.5
Pump Motor	kW	52(30+22)	59(37+22)	67(45+22)	82(60+22)
Heating Capacity	kw	18.5	25	32	41
NO of Heater Zones	unit	6	6	6	8
<b>General Unit</b>					
Oil Tank Capacity	L	520	520	600	730
Machine Dimensions (LxWxH)	m×m×m	7.5x2.35x2.2	7.5x2.35x2.2	7.6x2.35x2.2	8.26x2.35x2.2
Machine Weight	KG	19000	20000	20000	22000

## Appearance and Installation Dimensions

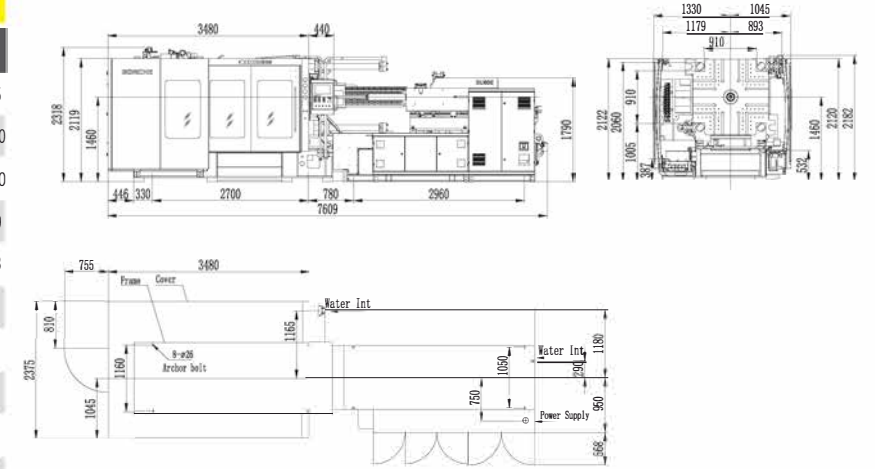

## Mold Platen Drawing

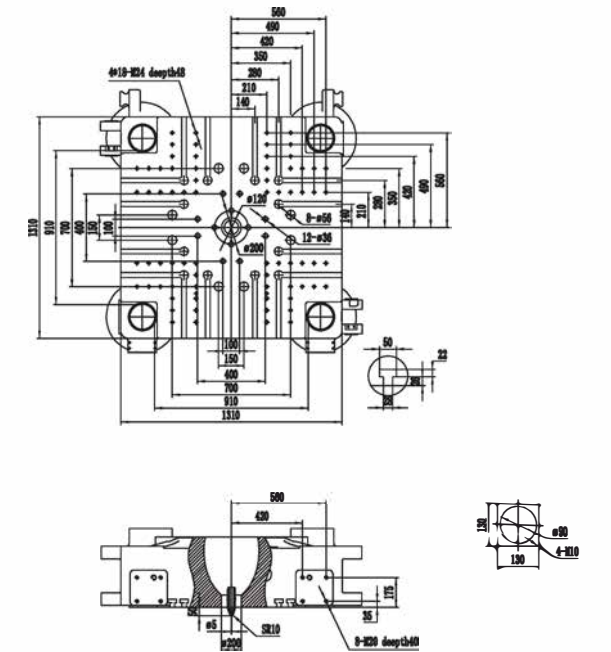

### DESCRIPTION

MOLDEL INTERNATIONAL CLASS NO.	UNIT	BU700-V			
		3266	4155	5700	7400
<b>Injection Unit</b>					
Screw Diameter	mm	70 80 90 80 85 95	90 100 105	100 105 115	
Shot Volume	cm <sup>3</sup>	1539 2011 2545	2262 2554 3190	3181 3927 4330	4123 4546 5453
Shot Weight(PS)	g	1401 1830 2316	2058 2324 2903	2895 3574 3940	3752 4137 4962
Shot Weight(PS)	OZ	49 65 82	73 82 102	102 126 139	132 146 175
Injection Pressure	Mpa	212 162 128	184 163 130	181 147 133	180 163 136
Screw L/D Ratio	L/d	24 21 19	22.3 21 19	25 22.5 21	24 23 21
Injection Stroke	mm	400	450	500	525
Screw Rotary Speed Max	rpm	170	168	134	115
Nozzle Contact Force	KN	80	80	200	200
Nozzle Stroke	mm	620	620	675	770
<b>Clamping Unit</b>					
Clamping Force	KN			7000	
Mould Opening Stroke	mm			1500 / 950	
Platen Size:HxW	mm×mm			1500x1350	
Space Between Tie Bars:HxV	mm×mm			1060x910	
Daylight Max	mm			1900	
Mold Thickness (min-max)	mm			400-950	
Ejector Stroke	mm			300	
Ejector Force	KN			210	
Ejector Pin Hole	unit			8+8+4+1	
<b>Power Unit</b>					
System pressure	Mpa	17.5	17.5	17.5	17.5
Pump Motor	kW	59(37+22)	67(45+22)	82(60+22)	97(60+37)
Heating Capacity	kw	25	32	41	47
NO of Heater Zones	unit	6	6	8	8
<b>General Unit</b>					
Oil Tank Capacity	L	520	600	730	960
Machine Dimensions (LxWxH)	m×m×m	7.85x2.87x2.4	7.94x2.87x2.4	8.6x2.87x2.4	8.97x2.87x2.4
Machine Weight	KG	24000	24000	26000	28000

### Appearance and Installation Dimensions

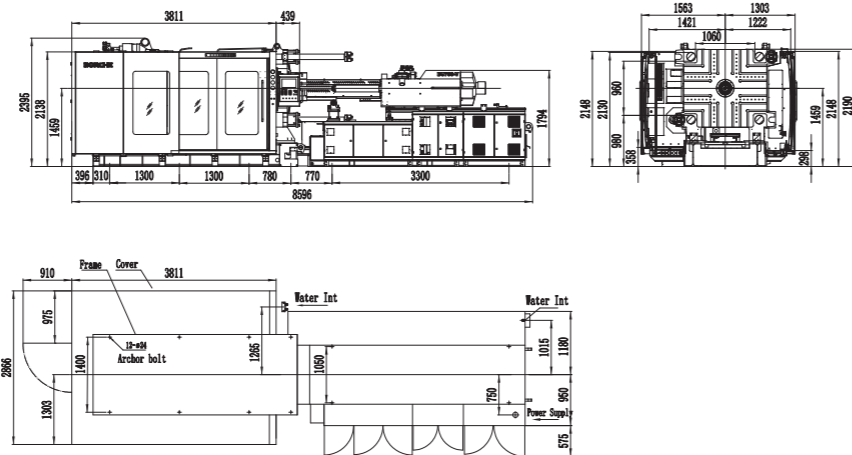

### Mold Platen Drawing

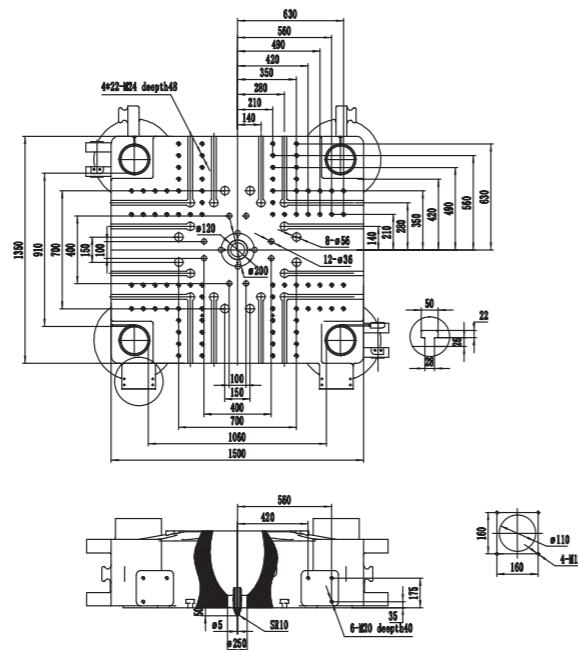

### DESCRIPTION

MOLDEL INTERNATIONAL CLASS NO.	UNIT	BU800-V			
		3266	4155	5700	7400
<b>Injection Unit</b>					
Screw Diameter	mm	70 80 90 80 85 95	90 100 105	100 105 115	
Shot Volume	cm <sup>3</sup>	1539 2011 2545	2262 2554 3190	3181 3927 4330	4123 4546 5453
Shot Weight(PS)	g	1401 1830 2316	2058 2324 2903	2895 3574 3940	3752 4137 4962
Shot Weight(PS)	OZ	49 65 82	73 82 102	102 126 139	132 146 175
Injection Pressure	Mpa	212 162 128	184 163 130	181 147 133	180 163 136
Screw L/D Ratio	L/d	24 21 19	22.3 21 19	25 22.5 21	24 23 21
Injection Stroke	mm	400	450	500	525
Screw Rotary Speed Max	rpm	199	168	134	115
Nozzle Contact Force	KN	80	80	200	200
Nozzle Stroke	mm	620	620	675	770
<b>Clamping Unit</b>					
Clamping Force	KN			8000	
Mould Opening Stroke	mm			1600 / 1000	
Platen Size:HxW	mm×mm			1550x1450	
Space Between Tie Bars:HxV	mm×mm			1110x1010	
Daylight Max	mm			2000	
Mold Thickness (min-max)	mm			400-1000	
Ejector Stroke	mm			300	
Ejector Force	KN			210	
Ejector Pin Hole	unit			8+8+4+1	
<b>Power Unit</b>					
System pressure	Mpa	17.5	17.5	17.5	17.5
Pump Motor	kW	67(45+22)	67(45+22)	82(60+22)	97(60+37)
Heating Capacity	kw	25	32	41	47
NO of Heater Zones	unit	6	6	8	8
<b>General Unit</b>					
Oil Tank Capacity	L	520	600	730	960
Machine Dimensions (LxWxH)	m×m×m	7.85x2.87x2.4	7.94x2.87x2.4	8.6x2.87x2.4	8.97x2.87x2.4
Machine Weight	KG	26000	26000	28000	30000

### Appearance and Installation Dimensions

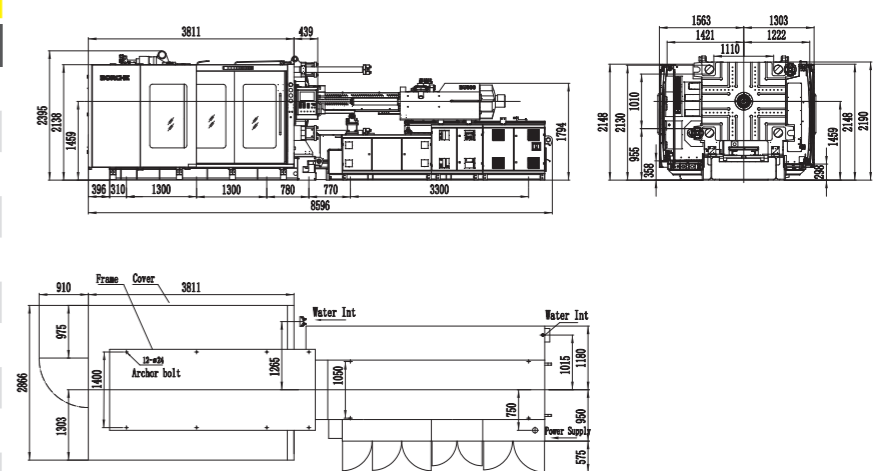

### Mold Platen Drawing

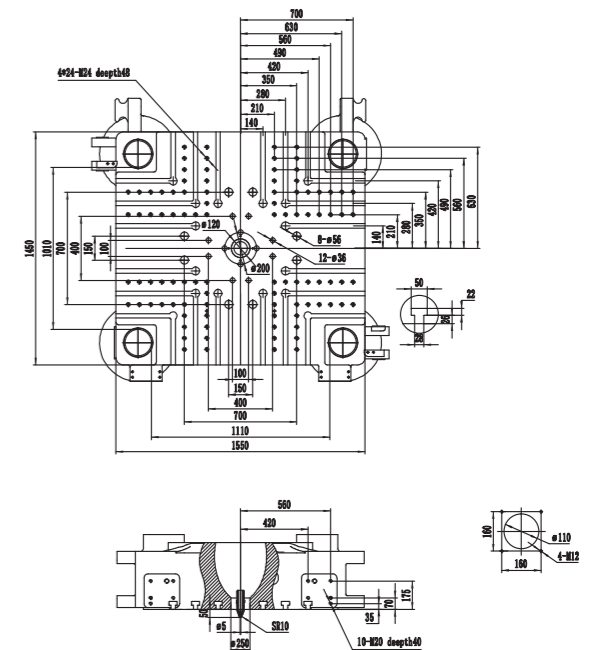

# BU900-V

# BORCHE

## DESCRIPTION

MOLDEL INTERNATIONAL CLASS NO.	UNIT	BU900-V			
		4155	5700	7400	11500
<b>Injection Unit</b>					
Screw Diameter	mm	80 85 95 90 100 105	<b>100 105 115</b>	105 115 130	
Shot Volume	cm <sup>3</sup>	2262 2554 3190 3181 3927 4330	<b>4123 4546 5453</b>	5195 6232 7964	
Shot Weight(PS)	g	2058 2324 2903 2895 3574 3940	<b>3752 4137 4962</b>	4728 5671 7247	
Shot Weight(PS)	OZ	73 82 102 102 126 139	<b>132 146 175</b>	167 200 256	
Injection Pressure	Mpa	184 163 130 181 147 133	<b>180 163 136</b>	221 184 144	
Screw L/D Ratio	L/d	22.3 21 19 25 22.5 21	<b>24 23 21</b>	24 22 20	
Injection Stroke	mm	450	500	525	600
Screw Rotary Speed Max	rpm	168	134	115	110
Nozzle Contact Force	KN	80	200	200	200
Nozzle Stroke	mm	620	675	770	850
<b>Clamping Unit</b>					
Clamping Force	KN	9000			
Mould Opening Stroke	mm	1700 / 1150			
Platen Size:HxV	mm×mm	1670×1540			
Space Between Tie Bars:HxV	mm×mm	1180×1050			
Daylight Max	mm	2200			
Mold Thickness (min-max)	mm	500-1050			
Ejector Stroke	mm	350			
Ejector Force	KN	210			
Ejector Pin Hole	unit	8+8+1			
<b>Power Unit</b>					
System pressure	Mpa	17.5	17.5	17.5	17.5
Pump Motor	kW	75(45+30)	82(60+22)	97(60+37)	127(60+45+22)
Heating Capacity	kw	32	41	47	68
NO of Heater Zones	unit	6	8	8	8
<b>General Unit</b>					
Oil Tank Capacity	L	600	730	960	1250
Machine Dimensions (LxWxH)	m×m×m	8.35x3.2x3.1	9.01x3.2x3.1	9.4x3.2x3.1	10.22x3.2x3.1
Machine Weight	KG	33000	35000	37000	39000

## Appearance and Installation Dimensions

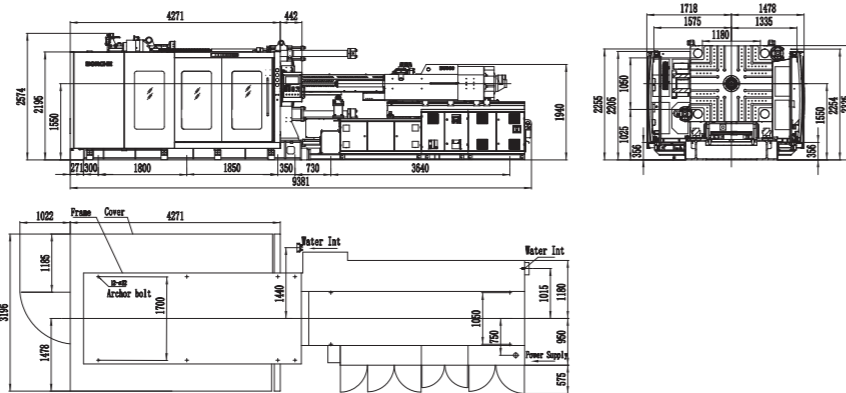

## Mold Platen Drawing

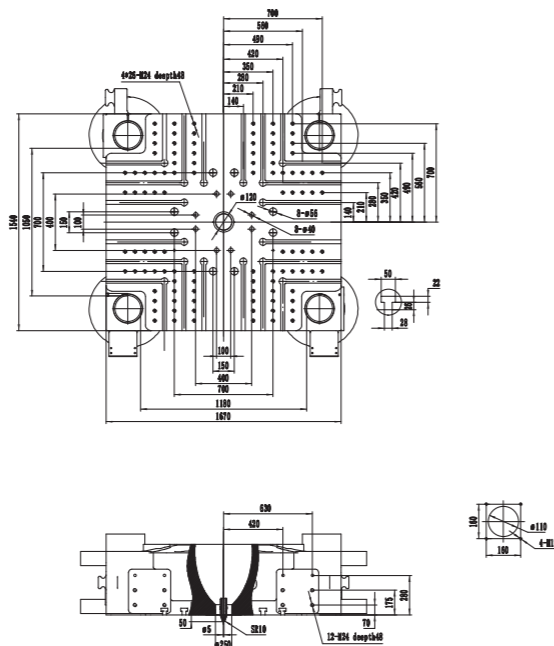

# BU1000-V

# BORCHE

## DESCRIPTION

MOLDEL INTERNATIONAL CLASS NO.	UNIT	BU1000-V			
		4155	5700	7400	11500
<b>Injection Unit</b>					
Screw Diameter	mm	80 85 95 90 100 105	<b>100 105 115</b>	105 115 130	
Shot Volume	cm <sup>3</sup>	2262 2554 3190 3181 3927 4330	<b>4123 4546 5453</b>	5195 6232 7964	
Shot Weight(PS)	g	2058 2324 2903 2895 3574 3940	<b>3752 4137 4962</b>	4728 5671 7247	
Shot Weight(PS)	OZ	73 82 102 102 126 139	<b>132 146 175</b>	167 200 256	
Injection Pressure	Mpa	184 163 130 181 147 133	<b>180 163 136</b>	221 184 144	
Screw L/D Ratio	L/d	22.3 21 19 25 22.5 21	<b>24 23 21</b>	24 22 20	
Injection Stroke	mm	450	500	525	600
Screw Rotary Speed Max	rpm	168	134	115	110
Nozzle Contact Force	KN	80	200	200	200
Nozzle Stroke	mm	620	675	770	850
<b>Clamping Unit</b>					
Clamping Force	KN	10000			
Mould Opening Stroke	mm	1800 / 1200			
Platen Size:HxV	mm×mm	1740×1515			
Space Between Tie Bars:HxV	mm×mm	1250×1025			
Daylight Max	mm	2300			
Mold Thickness (min-max)	mm	500-1100			
Ejector Stroke	mm	350			
Ejector Force	KN	210			
Ejector Pin Hole	unit	8+8+1			
<b>Power Unit</b>					
System pressure	Mpa	17.5	17.5	17.5	17.5
Pump Motor	kW	82(60+22)	82(60+22)	97(60+37)	127(60+45+22)
Heating Capacity	kw	32	41	47	68
NO of Heater Zones	unit	6	8	8	8
<b>General Unit</b>					
Oil Tank Capacity	L	600	730	960	1250
Machine Dimensions (LxWxH)	m×m×m	8.35x3.2x3.1	9.01x3.2x3.1	9.4x3.2x3.1	10.22x3.2x3.1
Machine Weight	KG	34000	36000	38000	40000

## Appearance and Installation Dimensions

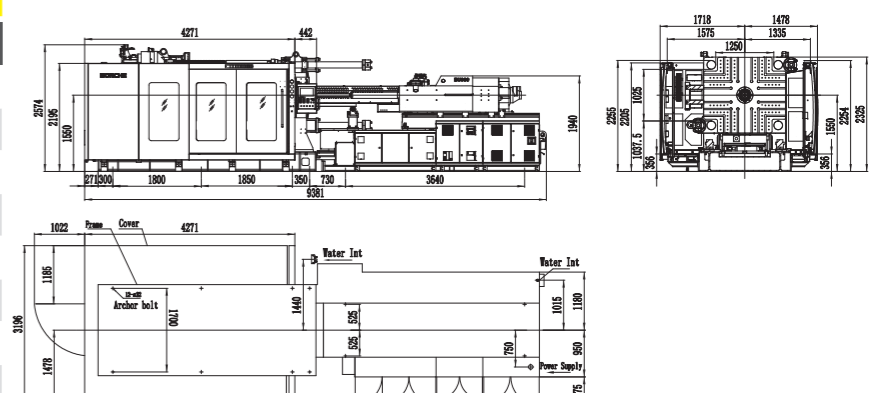

## Mold Platen Drawing

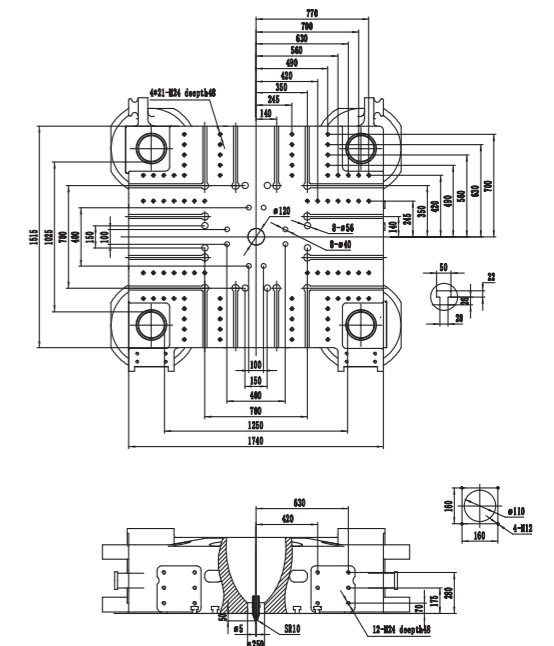



### DESCRIPTION

MOLDEL INTERNATIONAL CLASS NO.	UNIT	BU1200-V			
		5700	7400	11500	13500
<b>Injection Unit</b>					
Screw Diameter	mm	90 100 105 100 105 115	105 115 130	115 130 140	
Shot Volume	cm <sup>3</sup>	3181 3927 4330 4123 4546 5453	5195 6232 7964	6751 8628 10006	
Shot Weight(PS)	g	2895 3574 3940 3752 4137 4962	4728 5671 7247	6144 7851 9105	
Shot Weight(PS)	OZ	102 126 139 132 146 175	167 200 256	217 277 321	
Injection Pressure	Mpa	181 147 133 180 163 136	221 184 144	200 157 135	
Screw L/D Ratio	L/d	25 22.5 21 24 23 21	24 22 20	25 22 20.5	
Injection Stroke	mm	500	525	600	650
Screw Rotary Speed Max	rpm	134	115	110	105
Nozzle Contact Force	KN	200	200	200	200
Nozzle Stroke	mm	675	770	850	900
<b>Clamping Unit</b>					
Clamping Force	KN	12000			
Mould Opening Stroke	mm	2000 / 1400			
Platen Size:HxV	mm×mm	1920x1820			
Space Between Tie Bars:HxV	mm×mm	1300x1200			
Daylight Max	mm	2600			
Mold Thickness (min-max)	mm	600-1200			
Ejector Stroke	mm	380			
Ejector Force	KN	300			
Ejector Pin Hole	unit	8+8+8+1			
<b>Power Unit</b>					
System pressure	Mpa	17.5	17.5	17.5	17.5
Pump Motor	kW	82(60+22)	97(60+37)	127(60+45+22)	135(60+45+30)
Heating Capacity	kw	41	47	68	79
NO of Heater Zones	unit	8	8	8	9
<b>General Unit</b>					
Oil Tank Capacity	L	730	960	1250	1250
Machine Dimensions (LxWxH)	m×m×m	9.74x3.32x3.6	10.11x3.32x3.6	10.94x3.32x3.6	10.97x3.32x3.6
Machine Weight	KG	44000	46000	48000	50000

### Appearance and Installation Dimensions

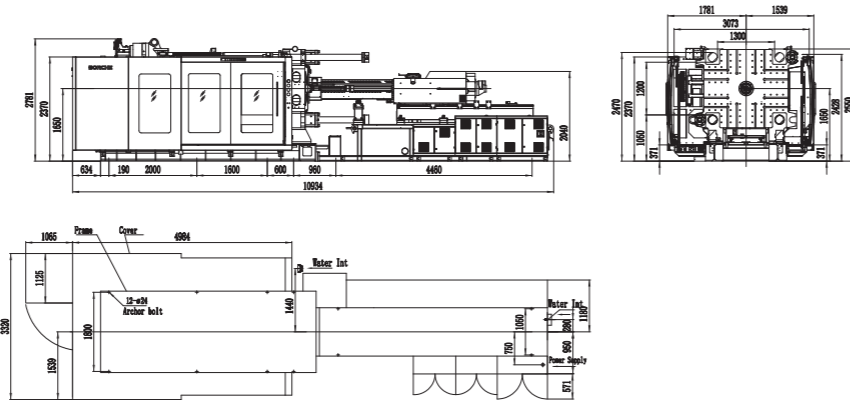

### Mold Platen Drawing

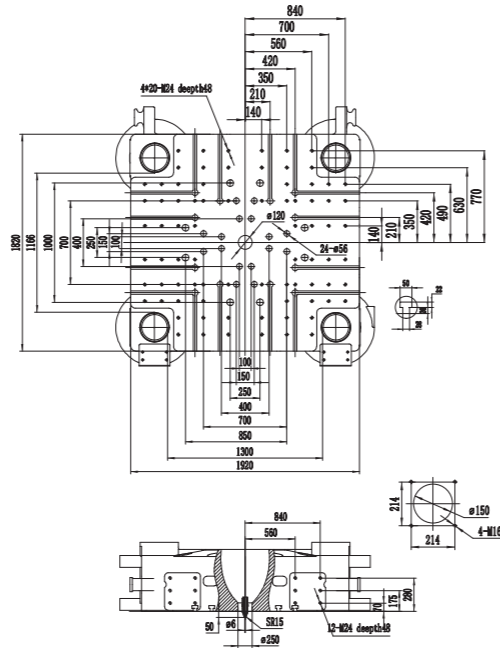

### DESCRIPTION

MOLDEL INTERNATIONAL CLASS NO.	UNIT	BU1350-V			
		7400	11500	13500	17650
<b>Injection Unit</b>					
Screw Diameter	mm	100 105 115 105 115 130	115 130 140	130 140 150	
Shot Volume	cm <sup>3</sup>	4123 4546 5453 5195 6232 7964	6751 8628 10006	9291 10776 12370	
Shot Weight(PS)	g	3752 4137 4962 4728 5671 7247	6144 7851 9105	8455 9806 11257	
Shot Weight(PS)	OZ	132 146 175 167 200 256	217 277 321	298 346 397	
Injection Pressure	Mpa	180 163 136 221 184 144	200 157 135	191 164 143	
Screw L/D Ratio	L/d	24 23 21 24 22 20	25 22 20.5	24 22 21	
Injection Stroke	mm	525	600	650	700
Screw Rotary Speed Max	rpm	115	110	105	102
Nozzle Contact Force	KN	200	200	200	200
Nozzle Stroke	mm	770	850	900	965
<b>Clamping Unit</b>					
Clamping Force	KN	13500			
Mould Opening Stroke	mm	2250 / 1550			
Platen Size:HxV	mm×mm	1990×1890			
Space Between Tie Bars:HxV	mm×mm	1420×1300			
Daylight Max	mm	2900			
Mold Thickness (min-max)	mm	650-1350			
Ejector Stroke	mm	380			
Ejector Force	KN	300			
Ejector Pin Hole	unit	8+8+8+1			
<b>Power Unit</b>					
System pressure	Mpa	17.5	17.5	17.5	17.5
Pump Motor	kW	105(60+45)	127(60+45+22)	135(60+45+30)	165(60+45+45)
Heating Capacity	kw	47	68	79	81
NO of Heater Zones	unit	8	8	9	9
<b>General Unit</b>					
Oil Tank Capacity	L	960	1250	1250	1550
Machine Dimensions (LxWxH)	m×m×m	10.27x3.5x3.6	11.1x3.5x3.6	11.2x3.5x3.6	11.91x3.5x3.6
Machine Weight	KG	52000	54000	56000	58000

### Appearance and Installation Dimensions

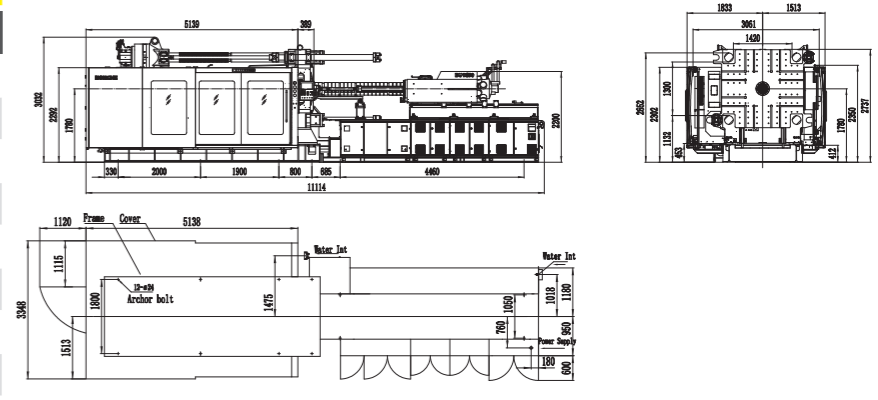

### Mold Platen Drawing

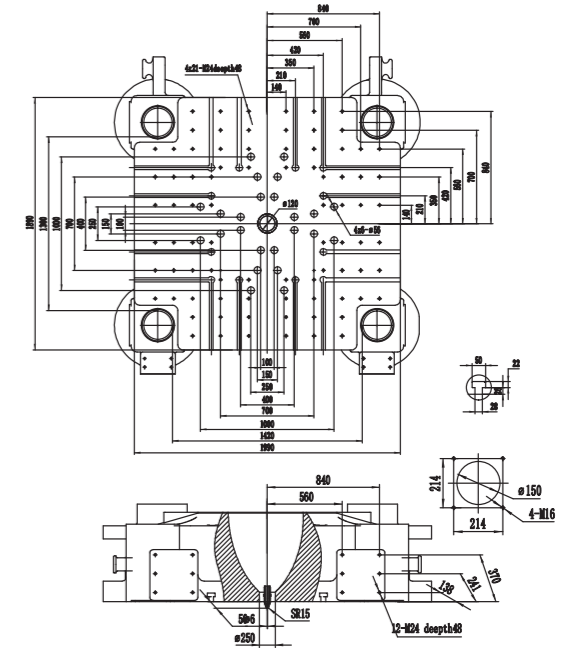

## DESCRIPTION

MOLDEL INTERNATIONAL CLASS NO.	UNIT	BU1500-V			
		7400	11500	13500	17650
<b>Injection Unit</b>					
Screw Diameter	mm	100 105 115 105 115 130	115 130 140 130 140 150		
Shot Volume	cm <sup>3</sup>	4123 4546 5453 5195 6232 7964	6751 8628 10006	9291 10776 12370	
Shot Weight(PS)	g	3752 4137 4962 4728 5671 7247	6144 7851 9105	8455 9806 11257	
Shot Weight(PS)	OZ	132 146 175 167 200 256	217 277 321	298 346 397	
Injection Pressure	Mpa	180 163 136 221 184 144	200 157 135	191 164 143	
Screw L/D Ratio	L/d	24 23 21 24 22 20	25 22 20.5	24 22 21	
Injection Stroke	mm	525 600 650 700			
Screw Rotary Speed Max	rpm	115 110 105 102			
Nozzle Contact Force	KN	200 200 200 200			
Nozzle Stroke	mm	770 850 900 965			
<b>Clamping Unit</b>					
Clamping Force	KN	15000			
Mould Opening Stroke	mm	2400 / 1700			
Platen Size:HxW	mm×mm	2120×2120			
Space Between Tie Bars:HxV	mm×mm	1480×1480			
Daylight Max	mm	3100			
Mold Thickness (min-max)	mm	700-1400			
Ejector Stroke	mm	380			
Ejector Force	KN	300			
Ejector Pin Hole	unit	8+8+8+1			
<b>Power Unit</b>					
System pressure	Mpa	17.5 17.5 17.5 17.5			
Pump Motor	kW	105(60+45) 127(60+45+22) 135(60+45+30) 165(60+2+45)			
Heating Capacity	kw	47 68 79 81			
NO of Heater Zones	unit	8 8 9 9			
<b>General Unit</b>					
Oil Tank Capacity	L	960 1250 1250 1550			
Machine Dimensions (LxWxH)	m×m×m	10.41x3.5x3.6 11.24x3.5x3.6 11.28x3.5x3.6 11.97x3.5x3.6			
Machine Weight	KG	57000 59000 61000 63000			

## Appearance and Installation Dimensions

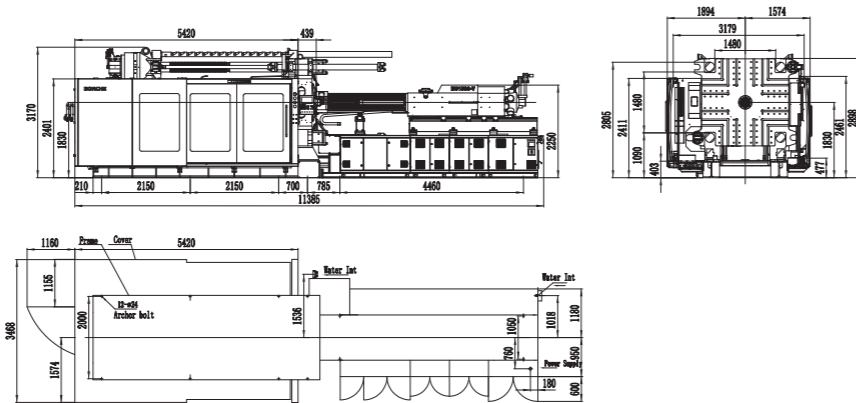

## Mold Platen Drawing

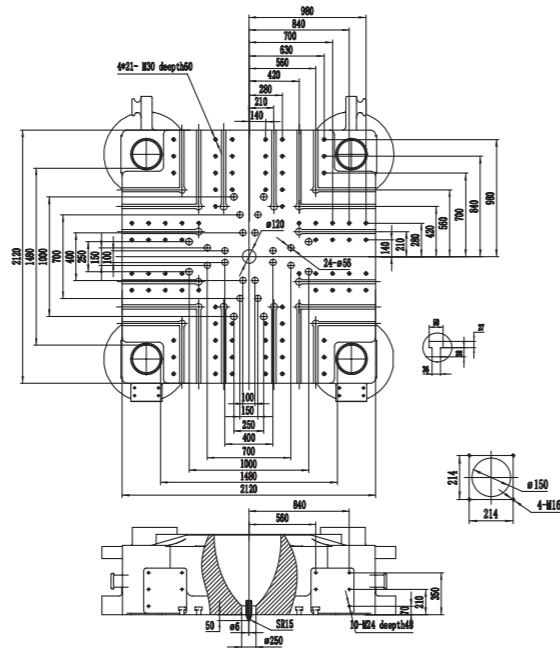

## DESCRIPTION

MOLDEL INTERNATIONAL CLASS NO.	UNIT	BU1650-V			
		11500	13500	17650	29500
<b>Injection Unit</b>					
Screw Diameter	mm	105 115 130 115 130 140	130 140 150 150 160 170		
Shot Volume	cm <sup>3</sup>	5195 6232 7964 6751 8628 10006	9291 10776 12370	16611 18900 21336	
Shot Weight(PS)	g	4728 5671 7247 6144 7851 9105	8455 9806 11257	15116 17199 19416	
Shot Weight(PS)	OZ	167 200 256 217 277 321	298 346 397	533 607 685	
Injection Pressure	Mpa	221 184 144 200 157 135	191 164 143	178 156 139	
Screw L/D Ratio	L/d	24 22 20 25 22 20.5	24 22 21	23 21.6 20	
Injection Stroke	mm	600 650 700 940			
Screw Rotary Speed Max	rpm	110 105 102 82			
Nozzle Contact Force	KN	200 200 200 290			
Nozzle Stroke	mm	850 900 965 1110			
<b>Clamping Unit</b>					
Clamping Force	KN	16500			
Mould Opening Stroke	mm	2500 / 1700			
Platen Size:HxV	mm×mm	2215x2115			
Space Between Tie Bars:HxV	mm×mm	1580x1480			
Daylight Max	mm	3200			
Mold Thickness (min-max)	mm	700-1500			
Ejector Stroke	mm	380			
Ejector Force	KN	300			
Ejector Pin Hole	unit	8+8+8+1			
<b>Power Unit</b>					
System pressure	Mpa	17.5 17.5 17.5 17.5			
Pump Motor	kW	135(60+45+30) 135(60+45+30) 165(60+2+45) 165(60+2+45)			
Heating Capacity	kw	68 79 81 97			
NO of Heater Zones	unit	8 9 9 9			
<b>General Unit</b>					
Oil Tank Capacity	L	1250 1250 1550 1750			
Machine Dimensions (LxWxH)	m×m×m	11.62x3.6x3.6 11.66x3.6x3.6 12.35x3.6x3.6 13.71x3.6x3.6			
Machine Weight	KG	66000 68000 70000 78000			

## Appearance and Installation Dimensions

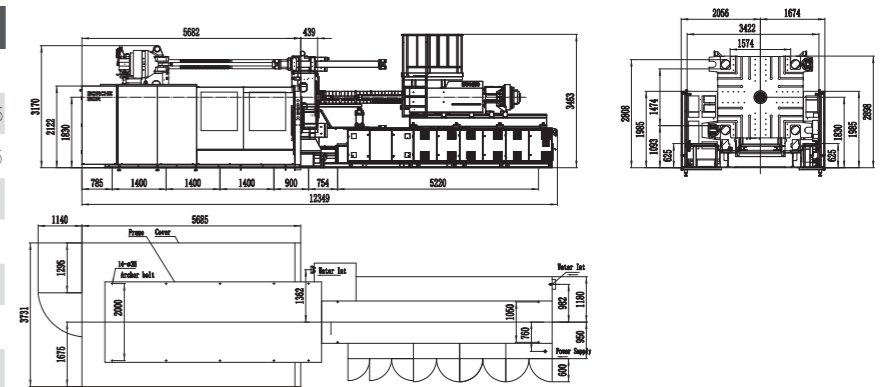

## Mold Platen Drawing

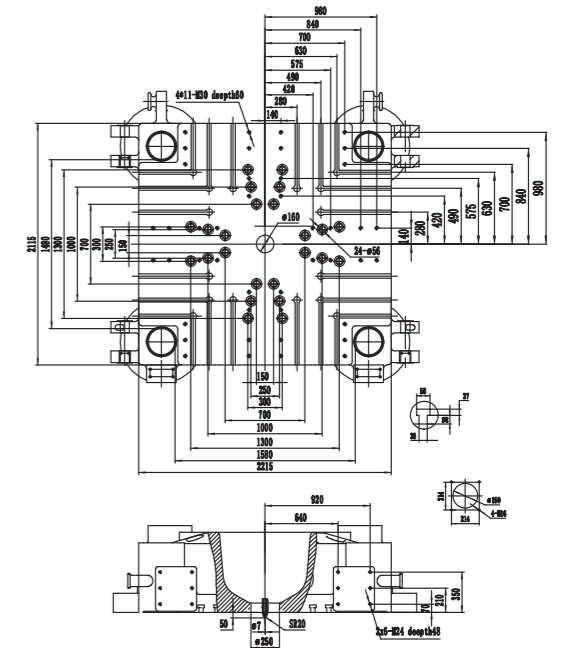

### DESCRIPTION

MOLDEL INTERNATIONAL CLASS NO.	UNIT	BU1800-V			
		11500	13500	17650	29500
<b>Injection Unit</b>					
Screw Diameter	mm	105 115 130 140	130 140 150 160 170		
Shot Volume	cm <sup>3</sup>	5195 6232 7964 6751 8628 10006	9291 10776 12370 16611 18900 21336		
Shot Weight(PS)	g	4728 5671 7247 6144 7851 9105	8455 9806 11257 15116 17999 19416		
Shot Weight(PS)	OZ	167 200 256 217 277 321	298 346 397 533 607 685		
Injection Pressure	Mpa	221 184 144 200 157 135	191 164 143 178 156 139		
Screw L/D Ratio	L/d	24 22 20 25 22 20.5	24 22 21 23 21.6 20		
Injection Stroke	mm	600 650 700 940			
Screw Rotary Speed Max	rpm	110 102 102 85			
Nozzle Contact Force	KN	200 200 200 290			
Nozzle Stroke	mm	850 900 965 1110			
<b>Clamping Unit</b>					
Clamping Force	KN		18000		
Mould Opening Stroke	mm		2500 / 1700		
Platen Size:HxW	mm×mm		2400×2240		
Space Between Tie Bars:HxV	mm×mm		1650×1550		
Daylight Max	mm		3200		
Mold Thickness (min-max)	mm		700-1500		
Ejector Stroke	mm		380		
Ejector Force	KN		300		
Ejector Pin Hole	unit		8+8+8+1		
<b>Power Unit</b>					
System pressure	Mpa	17.5 17.5 17.5 17.5			
Pump Motor	kW	135(60+45+30) 135(60+45+30) 165(60+45) 180(60+60+60)			
Heating Capacity	kw	68 79 81 97			
NO of Heater Zones	unit	8 9 9 9			
<b>General Unit</b>					
Oil Tank Capacity	L	1250 1250 1550 1750			
Machine Dimensions (LxWxH)	m×m×m	11.62×3.8×3.6 11.66×3.8×3.6 12.35×3.8×3.6 13.7×3.8×3.6			
Machine Weight	KG	77000 79000 81000 89000			

### Appearance and Installation Dimensions

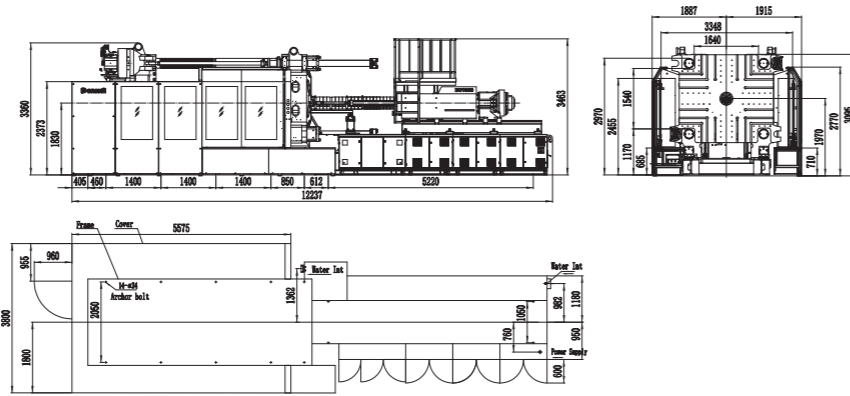

### Mold Platen Drawing

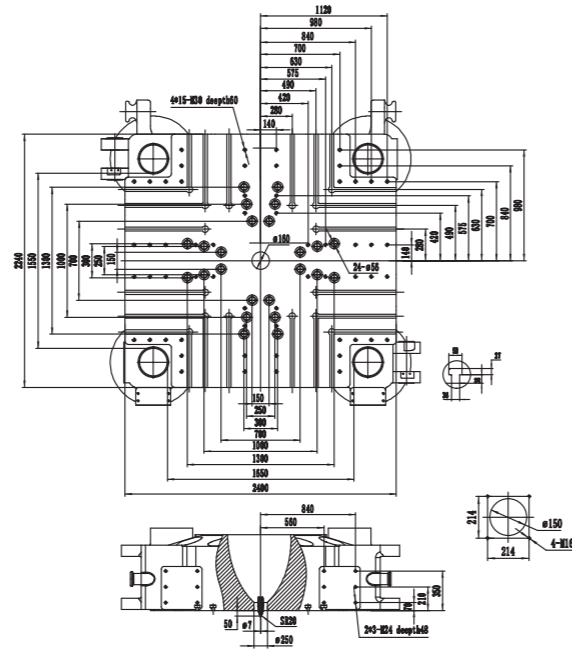

### DESCRIPTION

MOLDEL INTERNATIONAL CLASS NO.	UNIT	BU2200-V				
		11500	13500	17650	29500	40700
<b>Injection Unit</b>						
Screw Diameter	mm	105 115 130 140 150 160 170	150 160 170 185 195 205			
Shot Volume	cm <sup>3</sup>	5195 6232 7964 6751 8628 10006 9291 10776 12370 16611 18900 21336 19779 24864 30531				
Shot Weight(PS)	g	4728 5671 7247 6144 7851 9105 8455 9806 11257 15116 17999 19416 17999 22626 27783				
Shot Weight(PS)	OZ	167 200 256 217 277 321 298 346 397 533 607 685 635 798 980				
Injection Pressure	Mpa	221 184 144 200 157 135 191 164 143 178 156 139 207 165 134				
Screw L/D Ratio	L/d	24 22 20 25 22 20.5 24 22 21 23 21.6 20 26 23 21				
Injection Stroke	mm	600 650 700 940 925				
Screw Rotary Speed Max	rpm	110 120 102 85 72				
Nozzle Contact Force	KN	200 200 200 290 290				
Nozzle Stroke	mm	900 900 965 1110 1110				
<b>Clamping Unit</b>						
Clamping Force	KN		22000			
Mould Opening Stroke	mm		2800 / 1900			
Platen Size:HxW	mm×mm		2620×2370			
Space Between Tie Bars:HxV	mm×mm		1850×1600			
Daylight Max	mm		3600			
Mold Thickness (min-max)	mm		800-1700			
Ejector Stroke	mm		450			
Ejector Force	KN		390			
Ejector Pin Hole	unit		8+8+8+1			
<b>Power Unit</b>						
System pressure	Mpa	17.5 17.5 17.5 17.5 17.5				
Pump Motor	kW	165(60+45) 165(60+45) 165(60+45) 180(60+60+60) 199(60+45)				
Heating Capacity	kw	68 79 81 97 116				
NO of Heater Zones	unit	8 9 9 9 15				
<b>General Unit</b>						
Oil Tank Capacity	L	1250 1250 1550 1750 2880				
Machine Dimensions (LxWxH)	m×m×m	12.38×4.0×3.8 12.42×4.0×3.8 13.11×4.0×3.8 14.5×4.0×3.8 15.5×4.0×3.8				
Machine Weight	KG	96000 98000 100000 108000 116000				

### Appearance and Installation Dimensions

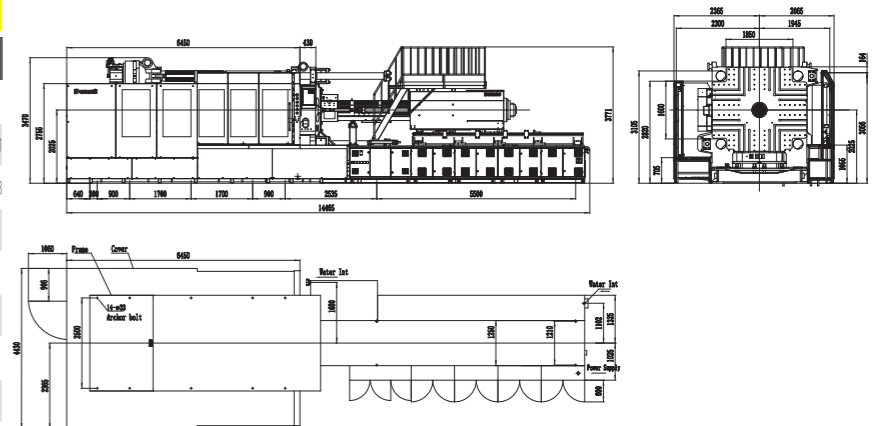

### Mold Platen Drawing

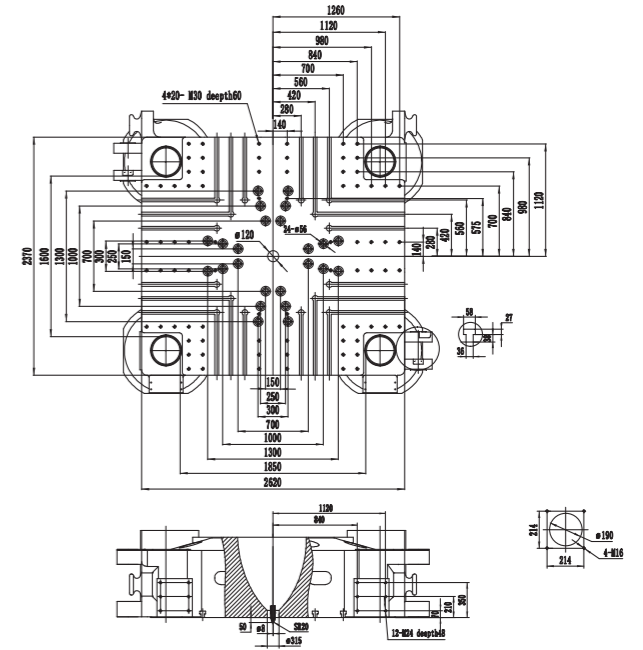

## DESCRIPTION

MOLDEL INTERNATIONAL CLASS NO.	UNIT	BU2500-V		
		17650	29500	40700
<b>Injection Unit</b>				
Screw Diameter	mm	130 140 150	150 160 170	165 185 205
Shot Volume	cm <sup>3</sup>	9291 10776 12370	16611 18900 21336	19779 24864 30531
Shot Weight(PS)	g	8455 9806 11257	15116 17199 19416	17999 22626 27783
Shot Weight(PS)	OZ	298 346 397	533 607 685	635 798 980
Injection Pressure	Mpa	191 164 143	178 156 139	207 165 134
Screw L/D Ratio	L/d	24 22 21	23 21.6 20	26 23 21
Injection Stroke	mm	700	940	925
Screw Rotary Speed Max	rpm	110	85	72
Nozzle Contact Force	KN	200	290	290
Nozzle Stroke	mm	965	110	1110
<b>Clamping Unit</b>				
Clamping Force	KN	25000		
Mould Opening Stroke	mm	2800 / 1900		
Platen Size:HxW	mm×mm	2740x2540		
Space Between Tie Bars:HxV	mm×mm	1950x1750		
Daylight Max	mm	3600		
Mold Thickness (min-max)	mm	800-1700		
Ejector Stroke	mm	450		
Ejector Force	KN	390		
Ejector Pin Hole	unit	8+8+8+1		
<b>Power Unit</b>				
System pressure	Mpa	17.5	17.5	17.5
Pump Motor	kW	176(94+60+22)	180(60+60+60)	199(94+60+45)
Heating Capacity	kw	81	97	176
NO of Heater Zones	unit	9	9	15
<b>General Unit</b>				
Oil Tank Capacity	L	1550	1750	2880
Machine Dimensions (LxWxH)	m×m×m	13.22x4.43x3.9	14.6x4.43x3.9	15.6x4.43x3.9
Machine Weight	KG	110000	118000	126000

## Appearance and Installation Dimensions

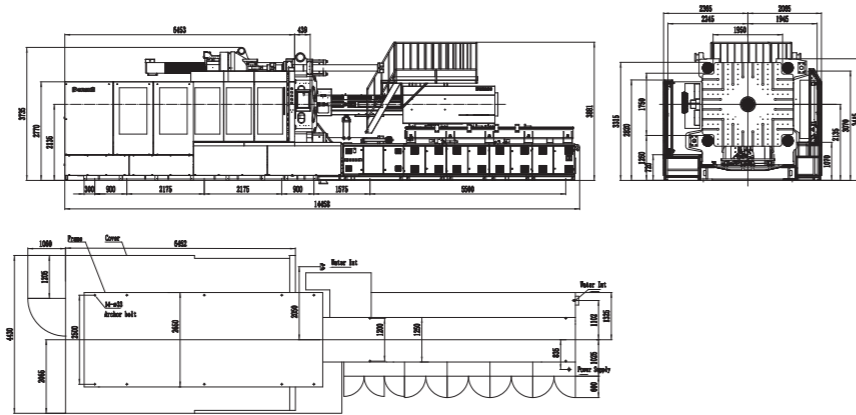

## Mold Platen Drawing

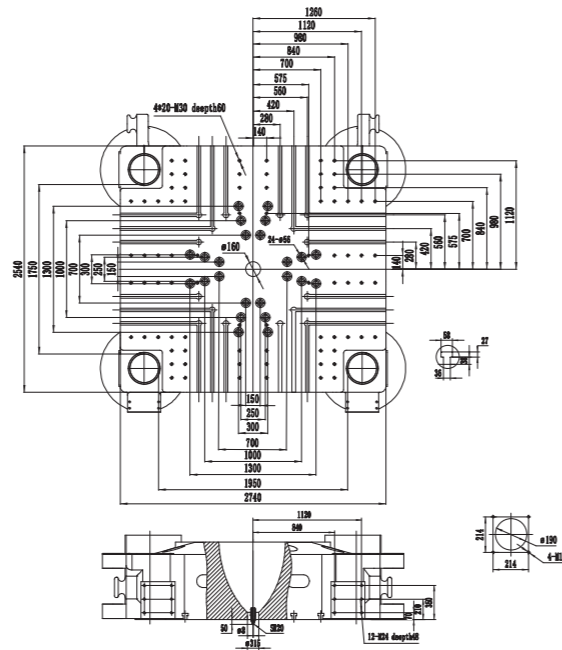

## DESCRIPTION

MOLDEL INTERNATIONAL CLASS NO.	UNIT	BU2800-V				
		17650	29500	40700	51400	64000
<b>Injection Unit</b>						
Screw Diameter	mm	130 140 150 160 170	165 185 205	205	215	
Shot Volume	cm <sup>3</sup>	9291 10776 12370 16611 18900 21336	19779 24864 30531	38287	45744	
Shot Weight(PS)	g	8455 9806 11257 15116 17199 19416	17999 22626 27783	34482	41627	
Shot Weight(PS)	OZ	298 346 397 533 607 685	635 798 980	1229	1468	
Injection Pressure	Mpa	191 164 143 178 156 139	207 165 134	134	140	
Screw L/D Ratio	L/d	24 22 21 23 21.6 20	26 23 21	21	21	
Injection Stroke	mm	700	940	925	1160	1260
Screw Rotary Speed Max	rpm	114	85	72	72	60
Nozzle Contact Force	KN	200	290	290	290	290
Nozzle Stroke	mm	965	110	110	1110	1110
<b>Clamping Unit</b>						
Clamping Force	KN	28000				
Mould Opening Stroke	mm	3100 / 2100				
Platen Size:HxW	mm×mm	2840x2640				
Space Between Tie Bars:HxV	mm×mm	2000x1800				
Daylight Max	mm	4000				
Mold Thickness (min-max)	mm	900-1900				
Ejector Stroke	mm	550				
Ejector Force	KN	550				
Ejector Pin Hole	unit	8+8+8+8+1				
<b>Power Unit</b>						
System pressure	Mpa	17.5	17.5	17.5	17.5	17.5
Pump Motor	kW	184(94+60+30)	180(60+60+60)	199(94+60+45)	214(60+2+94)	233(94+2+45)
Heating Capacity	kw	81	97	176	176	186
NO of Heater Zones	unit	9	9	15	15	15
<b>General Unit</b>						
Oil Tank Capacity	L	1550	1750	2880	2880	2880
Machine Dimensions (LxWxH)	m×m×m	14.0x4.77x3.9	15.35x4.77x3.9	16.35x4.77x3.9	16.35x4.77x3.9	17.24x4.77x3.9
Machine Weight	KG	126000	134000	142000	142000	146000

## Appearance and Installation Dimensions

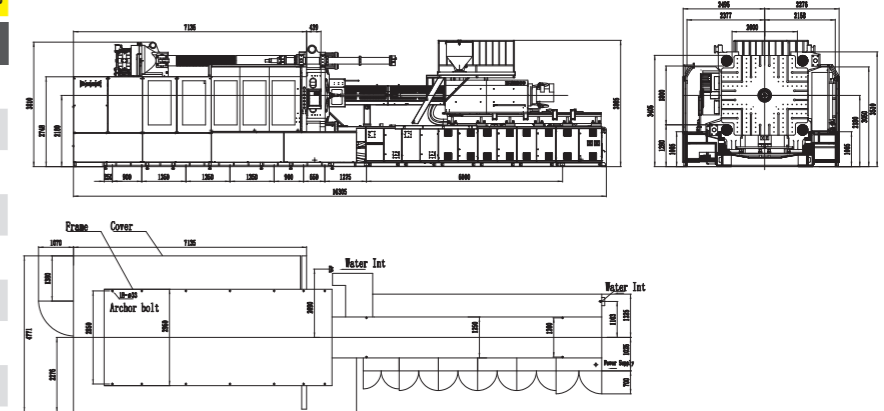

## Mold Platen Drawing

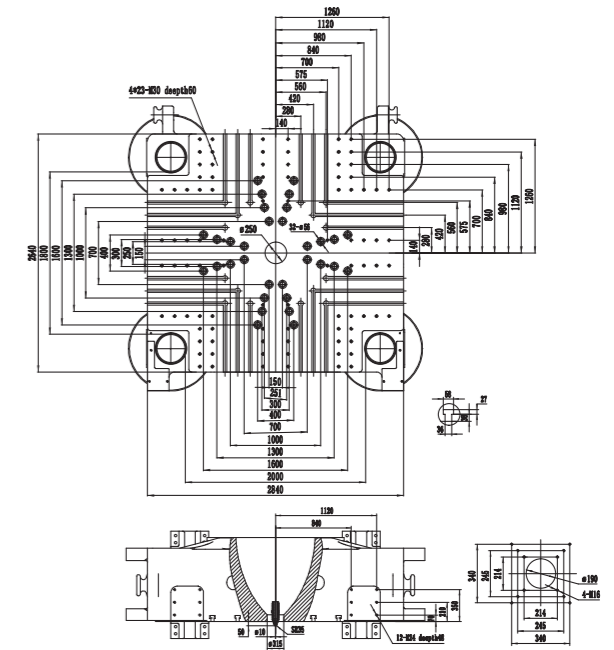

### DESCRIPTION

MODEL INTERNATIONAL CLASS NO.	UNIT	BU3300-V							
		17650	29500	40700	51400	64000			
<b>Injection Unit</b>									
Screw Diameter	mm	130	140	150	160	170	185	205	215
Shot Volume	cm <sup>3</sup>	9291	10776	12370	16611	18920	21336	19779	24664
Shot Weight(PS)	g	8455	9806	11257	15116	17189	19416	17399	22526
Shot Weight(PS)	OZ	298	346	397	533	607	685	635	798
Injection Pressure	Mpa	191	164	143	178	156	139	207	165
Screw L/D Ratio	L/d	24	22	21	23	216	20	26	23
Injection Stroke	mm	700	940	95	1160	1260			
Screw Rotary Speed Max	rpm	114	85	72	72	60			
Nozzle Contact Force	KN	200	290	290	290	290			
Nozzle Stroke	mm	95	100	110	110	110			
<b>Clamping Unit</b>									
Clamping Force	KN	33000							
Mould Opening Stroke	mm	3160 / 2160							
Platen Size:HxV	mm×mm	3060×2800							
Space Between Tie Bars:HxV	mm×mm	2160×1900							
Daylight Max	mm	4160							
Mold Thickness (min-max)	mm	1000-2000							
Ejector Stroke	mm	550							
Ejector Force	KN	550							
Ejector Pin Hole	unit	8+8+8+8+1							
<b>Power Unit</b>									
System pressure	Mpa	17.5	17.5	17.5	17.5	17.5			
Pump Motor	kW	184(94+60+30)	180(60+60+60)	199(94+60+45)	214(60+2+94)	233(94+2+45)			
Heating Capacity	kw	81	97	176	176	186			
NO of Heater Zones	unit	9	9	5	15	15			
<b>General Unit</b>									
Oil Tank Capacity	L	1550	1750	2880	2880	2880			
Machine Dimensions (LxWxH)	m×m×m	14.29x4.72x4.1	15.65x4.72x4.1	16.65x4.72x4.1	16.65x4.72x4.1	17.5x4.72x4.1			
Machine Weight	KG	14500	15400	16200	162000	166000			

### Appearance and Installation Dimensions

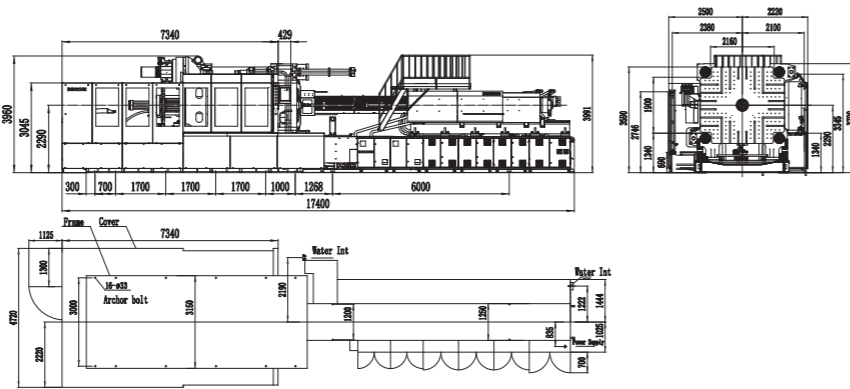

### Mold Platen Drawing

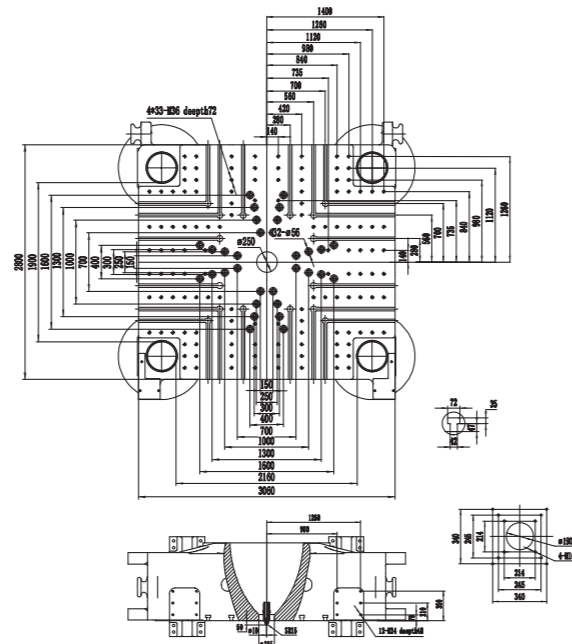

## Standard Features

SAFETY UNIT		
1	China New Safety Standard	●
2	Full covered design	●
3	Double emergency button (≤600T), four emergency button (≥700T)	●
INJECTION UNIT		
1	Twin carriage structure	●
2	Balancing twin injection cylinder	●
3	Wear resistant screw and barrel	●
4	3 sizes of screw/barrel available(ABC)	●
5	Nozzle centering calibration	●
6	Injection unit adopts linear guide rail	●
7	High torque hydraulic motor	●
8	Ceramic heater band	●
9	With screw and barrel support. (≥IU5700)	●
10	Bearing supported hopper slider (≤IU13500)	●
11	Hopper platform (≥IU17650)	●
12	Electric lock on nozzle cover	●
13	Protection cover on heater band	●
14	Nonslip embossed aluminum sheet	●
15	High pressure/temperature tube for cooling ring on hopper throat	●
16	Leakage protection when suckback	●
17	Screw RPM sensor	●
18	Screw cold start protection	●
19	4 ways of carriage backward	●
20	10 stages of injection, pressure/speed adjustable	●
21	10 stages of pressure holding, pressure/speed adjustable	●
22	5 stages of plasticizing, pressure/speed adjustable	●
23	Temp. sensor on hopper throat	●
CLAMPING UNIT		
1	Proportional valve for mold open and close	●
2	Anti-inclining and adjustable support for moving platen	●
3	Ejector backward position confirmation function	●
4	Pull back ejector pins	●
5	T-slot together with thread hole platen	●
6	Strong chrome plated tiebar	●
7	Synchronized half nut	●
8	Half nut independent lubrication	●
9	With robot mounting hole	●
10	Abrasion resistance strip	●
11	With hopper (≤600T)	●
12	Safety platform under mold area (≥700T)	●
13	Automatic safety door	●
14	Water manifold 9in/out, one on each platen(BU500-BU800)	●
15	Water manifold 10in/out, one on each platen(BU900-BU6800)	●
16	5 stages of closing/opening, pressure/speed adjustable	●
17	3stages/multi ways of ejector control(pressure, position, speed)	●
18	Auto mold thickness adjustment	●
19	Clamping force realtime monitor	●
20	Lubrication end pressure monitor	●
21	Magnetostrictive transducer for platen moving	●

HYDRAULIC UNIT		
1	Servo motor power	●
2	Low pressure mold protection	●
3	Parallel ejector/core	●
4	Spring mold function	●
5	4core pull(2 on fixed platen, 2 on moving platen). (≥1200T)	●
6	2 core pull(on moving platen). (≤1000T)	●
7	Efficient hydraulic oil cooler(≤IU4155)	●
8	Independent oil cooler(≥IU5700)	●
9	Bypass oil filter (≤IU4155)	●
10	Return filter(≥IU5700)	●
11	Pump with oil release function	●
12	High pressure 2-step release	●
13	Digital back pressure	●
14	One way valve for carriage	●
15	Boost open function	●
16	Low level alarm	●
17	Sucking filter with check valve(with sucking block alarm)	●
18	Explosion protective chain on hi-pressure pipes	●
19	High pressure mold opening function	●
CONTROL UNIT		
1	Keba controller	●
2	Internet connection port	●
3	Multi language available	●
4	Self diagnosis system	●
5	With SPC function	●
6	Process parameter quick setting	●
7	Robot interface	●
8	Auto purge	●
9	Timer heating function	●
10	Electric heating protection by fuse or auto switch	●
11	PID programmable barrel heating	●
12	Precise position sensor	●
13	With 2G CF card, capable for 200sets of parameter	●
14	Parameter lock	●
15	Solid relay temperature setting	●
16	3-color alarm	●
17	380V/32A/5P 3ph, 2 sets	●
18	380V/16A/5P 3ph, 2 sets	●
19	220V/10A socket, 1 sets	●
INTERCONNECTED UNIT		
1	Temporary authorization of OPC-UA/DA	●
2	PlasCloud App, basic version	●
2.1	Machine Kanban: status, cycle and output, etc.	●
2.2	Remote view: process parameter, SPC, machine setup	●
2.3	Machine management: spot check, maintenance, repair	●
2.4	Report: daily report, monthly report	●
OTHER UNIT		
1	Borche standard VI	●
2	Backup socket	●
3	Adjustable level pad	●
4	With standard tool kit	●
5	With standard spare parts set	●

### Optional Functions Of Intelligent Manufacturing:

1	With Industry 4.0 on IMM, three mold change ways can be realized with mold change platform: one-stop automatic mold change, semi-automatic mold change and manual mold change. IMM can automatically identify mold and acquire parameter of mold change, technique and peripherals. The hole of IMM should be tailored to suit that of the mold change platform and hydraulic clamp. IMM will evaluate the safety of above holes. Safety lock is active when matching signal received. IMM plays a responsible role in mold change platform and hydraulic clamp.
2	IMM controller can display all machines'(peripherals included)operation condition and malfunction alarm. There are eight malfunction alarm interfaces for following peripherals: one robot, two mould temperature controllers, one water cooler, one dryer and all-in-one compact dryer. The communication and alarm function of other peripherals are connected to IMM through external connection cabinet so that intelligent interconnection of IMM and peripherals is built.
3	Plug and play, intelligently inter-connected water cooler operated and controlled in IMM with close-loop connection Intelligent interconnection of IMM and chiller can be operated and controlled by IMM controller. Data is close-loop interconnection.
4	Intelligent interconnection of IMM and mould temperature controller can be operated and controlled by IMM controller. All data is close-loop interconnection.
5	Intelligent interconnection of IMM and all-in-one compact dryer can be operated and controlled by IMM controller. All data is close-loop interconnection.
6	Compression injection molding technique
7	High speed proportional valve for mold open and close and non-contact maglev linear transducer realize real-time monitor
8	Robot connects with IMM in real-time, which reduce the interference of robot, IMM and mold. Robot can be fixed on the top or side of fixed platen according to parts pick requirements
9	Automation system of IMM and peripherals interact with MES management system 1) Order Monitor 2) CProduction Status Display 3) Alarm Monitor 4) Technique Parameter Management 5) Equipment Management 6) Production Report
10	iPHM, IMM Prognoses and Health Management (Equipment Online Doctor ) 1) Safe and reliable bidirectional terminal is equipped with built-in firewall and remote VPN connection; various networking is available. Cloud platform connects IMM controller in real-time 2) Data of equipment operation, malfunction alarm and worker operation is collected in real time.IMM data visualization on Cloud Platform is realized. 3) Self diagnose module of failure and performance based one the dynamic data, can reduce the malfunction rate, and improve the equipment performance. 4) Operation and maintenance system connects the on-line management platform of after-sales service. It realizes remote on-line program upgrading, and improves the maintenance efficiency and quality. 5) IMM condition and performance report can be checked through mobile terminal; After-sales service request can be reported via WeChat.
11	Mold Visual Monitor 1) Low pressure mold protection for higher precision and efficiency 2) CAccurate checkup 3) Self-adaption to exterior light change 4) Self-adaption to inaccurate mold open position 5) Real-time record
12	Visual Detective System for surface quality checking 1) Fast detection, detection precision reaches to 0.001mm 2) Defectives check of contamination, color difference, flake, and short injection. 3) Wide application
13	Vision-induced System 1) Accurate positioning 2) Sensitive identification 3) Wide application

### 01 Factory Layout- Borche specializes in intelligent IMM factory design. Many intelligent factory cases carried out worldwide in IMM industry.

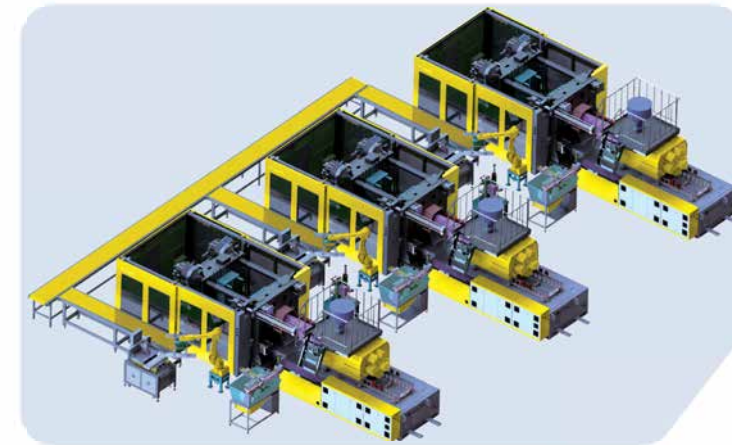

### 02 Flexible Automation -360° visual detection, robot operation, automatic assembling, parts insert, polishing and deburring...

Visual Detective System



Robot Application (part pick-up, casting insert, assembling, stacking, deburring, degating )

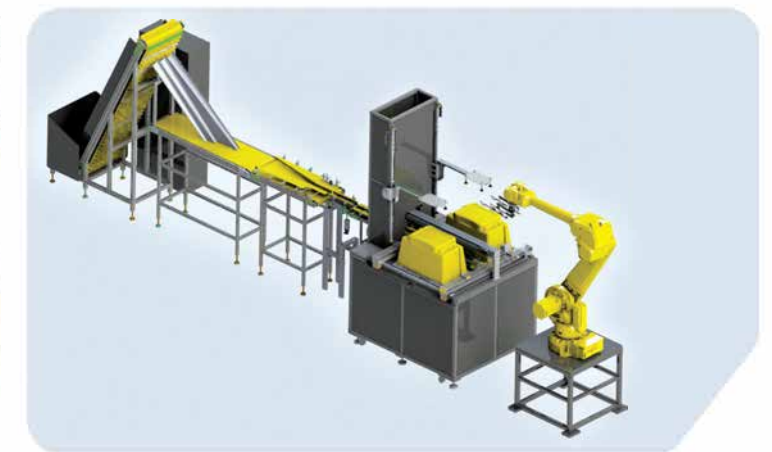

### 03 Intelligent Logistics- AGV, rolling line, automatic packing, wrapper.

