

HELIOS

Your perfect partner for material handling

HELIO®Clean

Dedusting system

Type series

HELIO®Clean 2

HELIO®Clean 3

HELIO®Clean Pro 10

HELIO®Clean Pro 20



2019

MADE IN GERMANY

 **CENTROTÉCNICA**

Ctra. Llobatona, 38
08840 Viladecans ▪ Barcelona
info@centrotecnica.es
www.centrotecnica.es
T. +34 936 376 868

www.helios-systems.com

HELIO®Clean dedusting devices for injection moulding processes

Professional cleaning of plastics before processing

Plastic processing, especially injection moulding, requires absolutely pure raw materials without dust, angel hair and other impurities for the production of high-quality parts.

Since these often only occur during conveying, HELIO®Clean granulate cleaners are combined conveying and dedusting systems for mounting on the processing machine, which transfer the perfectly dedusted granulate / regrind material directly into the plasticizing unit.

Dust is removed by means of air-floating with a highly effective ion shower. Due to its absolutely new fountain principle, this air washing process is able to perform even the most difficult cleaning tasks perfectly.

When selecting a deduster system, the choice shall be made:

As good as possible, or as good as necessary?

We offer both !

HELIOS always has the optimal solution for your dedusting task.

Minimal space requirement

Due to their compact construction, HELIO®Clean dedusting units can be mounted directly on the injection moulding machine or a drying container.



Problems with insufficiently dedusted resin

Product quality

- combustions (black dots)
- unmelted parts (white dots)
- streaks
- surface problems
- reduced mechanical properties

Injection moulding machine

- clogging and crust formation at the feeding zone
- abrasion on screw and barrel due to charred dust
- frequent machine downtime and high cleaning costs

Advantages of cleaning with HELIO®Clean dedusting units

By a professional cleaning of the material the quality of the resin can be brought back to its original state or the disturbing fines can be removed from the ground material.

better part quality

less scrap

more regrind can be used

less machine downtime

BEFORE



AFTER



PMMA raw granulate before and after dedusting.



HELIO®Clean - Milestones

- 2007 Deduster with compressed air jet
- 2008 Deduster integrated in JETBOX® dryer
- 2011 Deduster with integrated ejector
- 2012 Deduster with ionization
- 2014 Deduster with collecting unit
- 2016 Deduster with fountain and ion shower
- 2018 Deduster with blow cone and ion shower

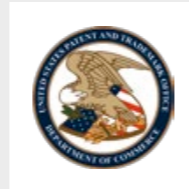

Conveying and dedusting device with ion shower

The new HELIO®Clean 3 conveyor / dedusting unit has been specially developed for injection moulding processes with small to medium throughputs and is suitable for mounting on the injection unit or a drying container.

- **small and powerful**
- **compact / low weight**
- **air separation with ion shower**
- **1- or 2-component version**
- **special glass construction**
- **simple operation**
- **optimum price/performance ratio**
- **cleaning by means of ions**

material throughput up to 25 kg/h*

* depending on material and required degree of dedusting
example based on PMMA/PC



Example: HELIO®Clean 3, compact version, 1 component

3-stage dedusting process

Air-floating with ion shower and dust suction

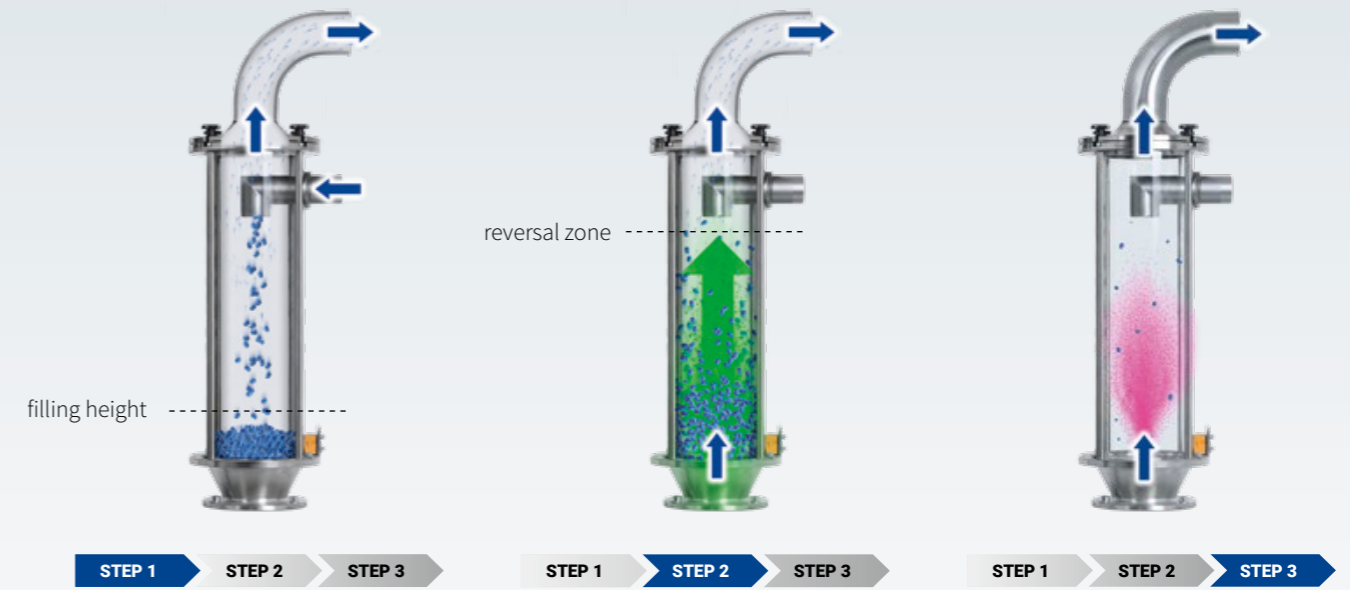

Filling

The material is gently conveyed into the sifting glass with simultaneous dust separation during filling.

Air floating + ion shower

Dust separation by air-floating with ionized air with freely adjustable whirling.

Cleaning

The sifter glass is cleaned and neutralised with ionized air between two filling processes.



Special glass construction

The dedusting chamber is made of abrasion-resistant special glass. This enables efficient cleaning with the aid of ions, as these are not neutralised immediately when they hit the sifter wall, but can release the binding forces between dust and material over a longer period of time. This design also enables the conveying and cleaning process to be viewed from all sides.

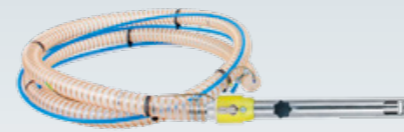

suction lance

Compressed air operated Venturi suction lance. Conveying height up to 8 m.



dust removal

The separated dust is removed into a separate dust collection container.

Ion shower

While the granulate is whirled up and circulated in the deduster, a continuous stream of ionized air is blown through the portion to be dedusted.

In this way, the binding forces between dust particles and granules are reduced to such an extent that the dust loosens and can be separated by air-floating.

Due to the special glass construction, the ions are particularly „long-lasting“ and therefore lead to a high efficiency of the ion shower.

- 1 **Insert ions**
- 2 **Neutralize charge**
- 3 **Separation by air-floating**



Assembly versions



Mounting on processing machine

Conveying and dedusting of the material directly on the feeding zone.
Intermediate container optionally with 0.5 / 2.0 or 5.0 liter volume.

Machine adapter with L-claw

HELIO®Clean 3 on injection unit



Mounting on drying container

Conveying with dedusting of the material on mobile dryer or top mounted dryer.

JETBOXX® dryer with HELIO®Clean 3



Split version

Installation of the control unit at a suitable place. So the weight on the drying container can be reduced or the control can be mounted at eye level in a user-friendly way.

JETBOXX® dryer on injection unit with HELIO®Clean 3 split version

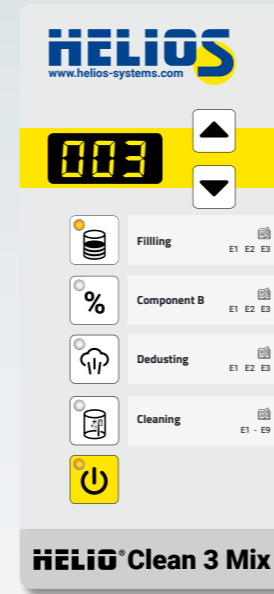

Example:
HELIO®Clean 3 MIX, compact version

HELIO®Clean 3 MIX

The MIX version can convey, dedust and homogenize regrind and virgin material in an adjustable mixing ratio.

The unit can be adjusted to any task effortlessly via 4 function keys with sub-levels.



Ionizer

A standard ionizer ensures optimum dust separation during air-floating and cleaning.



Gentle conveying

The conveying speed for each material component can be adjusted steplessly and material protectively.



Filling with air-floating

When filling with Venturi suction lances, the filling process is already combined with air-floating and ion shower.

Standard equipment

- compact version (control on device)
- 1-component version
- version for mounting on processing machine
- Venturi suction lance with 3 m conveying hose package
- dust collection container with 5 m dust removal hose
- special glass, abrasion-resistant and viewable from all sides

Options

- flange ring for mounting on drying container
- split version (control can be mounted separately)
- 2-component version HELIO®Clean 3 MIX
- conveying hose package long (5 m)
- dust collection container extension (+ 11 litre volume)
- intermediate container 0.5 / 2.0 or 5.0 litre
- machine adapter with L claws

Technical data

Material	special glass, stainless steel, Al nickel-plated
Material throughput	approx. 25 kg/h*
Conveying pipe	DN 32
Conveying height	max. 8 m
Electrical connection	~ 100 - 240 V AC, 50/60 Hz
Power consumption	max. 20 W
Pneumatic connection	min. 6 bar, 1/2"
Compressed air quality	max. oil content ≤ 0.01 mg/m ³
Temperature range	0 - 40 °C
Height	559 mm

*depending on the material to be dedusted and the required degree of dedusting

HELIO®Clean 2

Compressed air conveyor with dedusting function

The HELIO®Clean 2 conveyor / dedusting unit was specially developed for injection moulding and is suitable for mounting on a processing machine or a drying container.

■ compact and simple construction

■ 1- or 2-component version

■ simple operation

■ special glass construction

■ optimum price/performance ratio

material throughput **up to 25 kg/h***

* depending on material and required degree of dedusting



Example: HELIO®Clean 2, compact version, 1 component

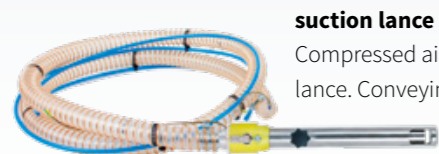

suction lance

Compressed air driven Venturi suction lance. Conveying height up to 8 m.



dust removal

The separated dust is removed into a separate dust collection container.

Dust removal process

Dust separation by compressed air jet and whirling



Step 1 → Step 2

Filling

Conveying using Venturi suction lance(s), the material is already dedusted during conveying, dust removal into the dust collection container.

Step 1 → Step 2

Whirling

Dedusting after each conveying process by 1 to 9 dedusting impulses by means of compressed air jet from above onto the dedusting portion, dust removal into the dust collection container.

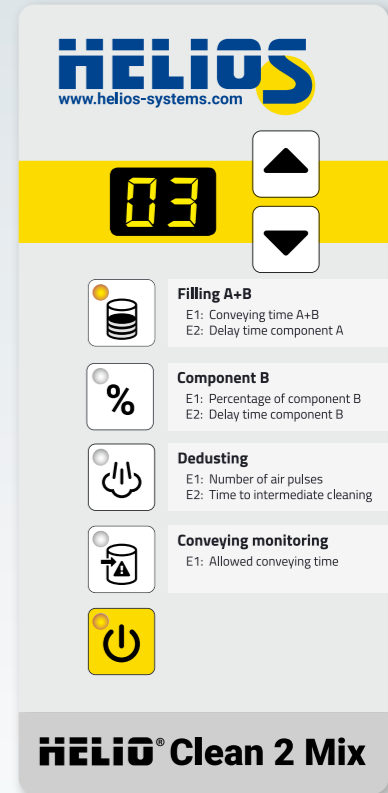

HELIO®Clean 2 MIX Version for 2 components

Regrind material and virgin material are conveyed, dedusted and homogenised.

Control by JETBOXX® dryers

JETBOXX® dryers from HELIOS can control up to two HELIO®Clean 2 dedusting units.

In this case, the control box on the dedusting and conveying unit is not required and all parameters for conveying and dedusting can be set directly on the dryer system control.

Please see also brochure JETBOXX® Dryer System

Conveying settings

Layering A/B	2.0 s
Component B	30 %
Permitted conveying time	99 s
Dedusting	3 x

WINsystem® dryer with option ME

HELIO®Clean 2 MIX as hopper loader on drying container



Option CE/ME



HELIO®Clean 2 on processing machine Control version CE as second conveying point of JETBOXX® dryer

Standard equipment

- version for mounting on processing machine with cone and machine adapter, type M
- 1-component version
- compact version (control on device)
- 3 m transport hose package with Venturi suction lance
- dust collection container + 5 m dust removal hose
- special glass, abrasion-resistant and viewable from all sides

Options

- version for mounting on drying container, type B
- split version (control can be mounted separately)
- 2-component version HELIO®Clean 2 MIX
- conveying hose package long (5 m)
- dust collection container extension (+ 11 litre volume)



Example: HELIO®Clean 2 MIX, split version, 2 components for mounting on drying container

Technical data

Material	special glass, stainless steel, Al nickel-plated
Material throughput	approx. 25 kg/h*
Conveying pipe	DN 32
Conveying height	max. 8 m
Electrical connection	~ 100 - 240 V AC, 50/60 Hz
Power consumption	max. 15 W
Pneumatic connection	min. 6 bar, 1/2"
Compressed air quality	max. oil content ≤ 0.01 mg/m ³
Temperature range	0 - 40 °C
Weight	4,9 kg
Height	358 mm

* depending on the material to be dedusted and the required degree of dedusting

HELIO®Clean Pro

perfect granulate cleaning with the HELIO®Clean Pro dedusting technology

An integrated conveyor system sucks resin/regrind into the dedusting chamber. The conveying speed can be preselected steplessly and new dust formation due to abrasion can be avoided.

A portion of exactly the same amount is gently dedusted by means of air-floating with an ion shower. The resin/regrind is sucked only as high that it does not touch the sieve disc at the dust outlet or leave the separator when the sieve disc is removed.

Safe removal of:

- dust
- splintering
- lint
- angel hair

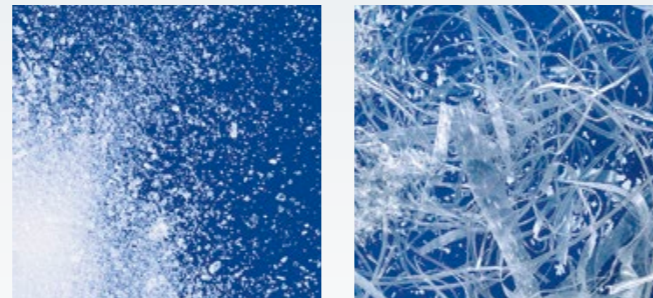

Fountain principle

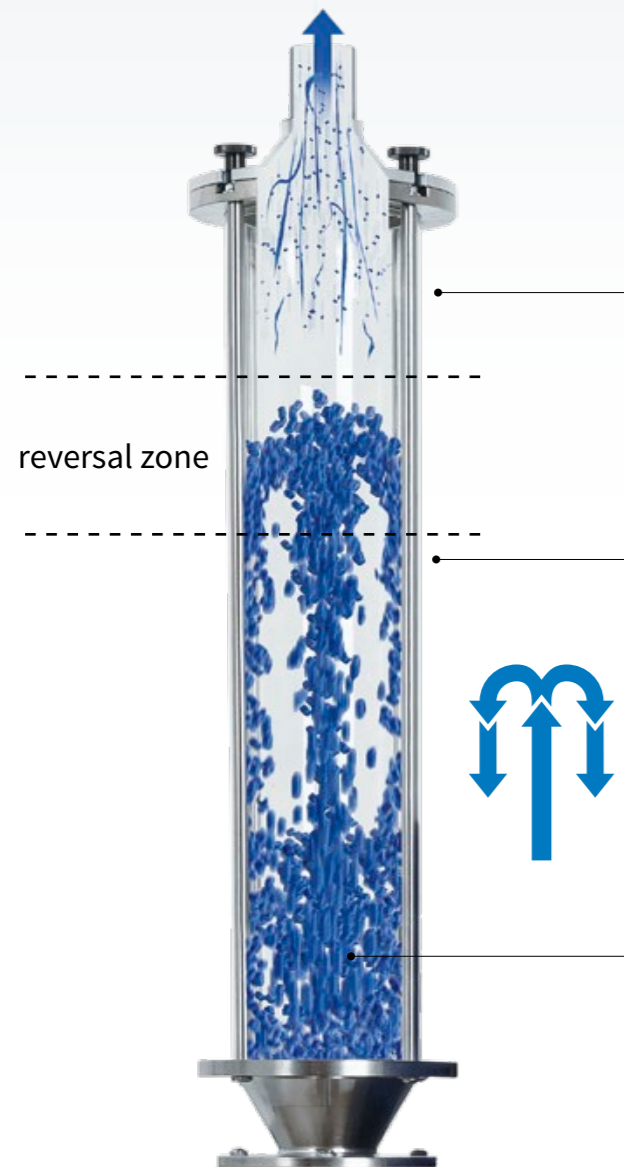

dust separation

Light parts such as dust or lint leave the separator at the top through the sieve disc and are separated into the dust collection container. HELIO®Clean Pro - devices without a sieve disc are even able to remove angel hair safely, which is produced when conveying plastic granulate.

material fountain

A laminar air stream with ionized air carries the material to be dedusted adjustable up to the upper third of the separator, where it reverses by gravity and returns to the starting point at the glass wall without leaving the open dedusting chamber (separator) at the bottom. This process is time-controlled, freely adjustable and repeats itself several times. Only after switching off the vacuum the dedusted portion is transferred to the intermediate container below.

special glass construction

The dedusting chamber is made of abrasion-resistant special glass. This allows efficient cleaning with the aid of ions, as these are not neutralized immediately when they hit the separator wall, but can release the binding forces between dust and material over a longer period of time. This design also enables the conveying and cleaning process to be viewed from all sides.

4-stage dedusting technology

Air-floating in fountain with ion shower and dedusting



Conveying

Pre-dedusting during filling by slow vacuum conveying with dust removal.

Loosening

Staged soft start with loosening and dust removal.

Air floating + ion shower

Gentle air-floating with ionized air. Fountain with laminar air flow and dust removal.

Cleaning

Automatic cleaning and neutralization of the separator glass by ionized air between two dedusting cycles and dust removal.

Ion shower

While the granulate is whirled up and circulated in the deduster, a continuous stream of ionized air is blown through the portion to be dedusted.

In this way, the binding forces between dust particles and granules are reduced to such an extent that the dust loosens and can be separated by air-floating.

Due to the special glass construction, the ions are particularly „long-lasting“ and therefore lead to a high efficiency of the ion shower.

- 1 Insert ions
- 2 Neutralize charge
- 3 Separation by air-floating



HELIO®Clean Pro 10



Granulate cleaner for injection moulding processes

The new HELIO®Clean Pro 10 conveying and dedusting device is specially developed for injection moulding and is characterised by particularly gentle conveying and dedusting with an ion shower.

■ 4-stage dedusting process

■ maximum dedusting degree

■ gentle dedusting

■ easy cleaning

■ control stand with cleaning aid

■ compact or split construction

■ 1- or 2-component version

■ air-floating with ion-cleaning
2x ionizer integrated

material throughput up to 35 kg/h*

* depending on material and required degree of dedusting
example based on PMMA/PC



Example: HELIO®Clean Pro 10 split version, 1 component (2 components optional)



Control stand

- system control
- vacuum generator with dust filter
- dust collection container
- filter cleaning
- cleaning set

Technical data

Material	special glass, stainless steel, Al nickel-plated
Filling capacity	up to 400 g
Material throughput	up to 35 kg/h*
Conveying pipe	DN 32
Conveying height	max. 8 m
Electrical connection	~ 100 - 240 V AC, 50/60 Hz
Power consumption	max. 25 W
Pneumatic connection	min. 6 bar, 1/2"
Compressed air quality	max. oil content ≤ 0.01 mg/m ³
Temperature range	0 - 40 °C

Assembly versions

B-version

for mounting on drying container

split construction



M-version

for mounting on processing machine

compact version

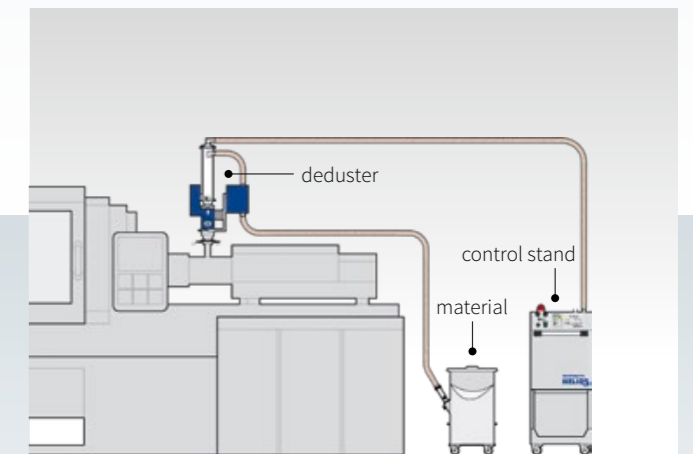
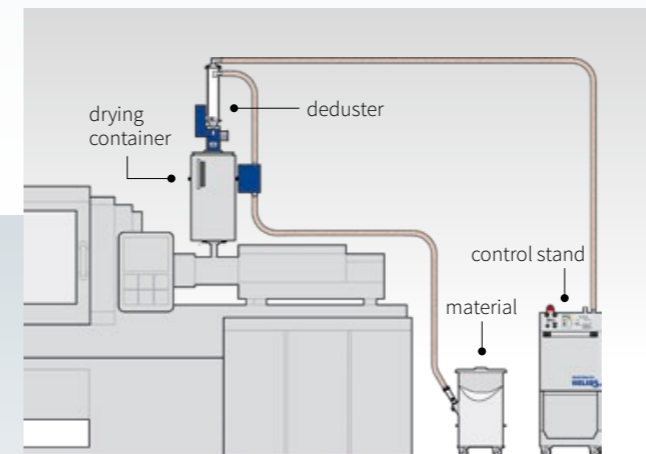
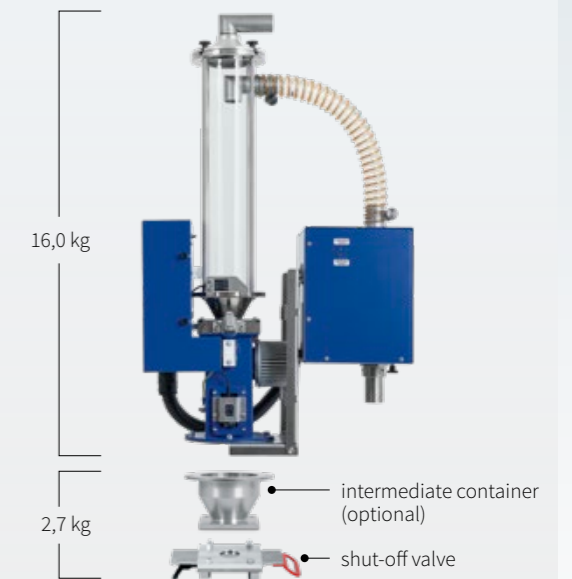

Removable valve box



The HELIO®Clean Pro 10 is delivered as a compact unit as standard. The valve box can be easily disassembled and attached to the desired position, e.g. hooked up to the container handle.

HELIO®Clean Pro 20

Granulate cleaner for injection moulding processes

The new HELIO®Clean Pro 20 is the most powerful HELIOS conveying and dedusting unit and was specially developed for injection moulding. It is characterized by particularly gentle conveying and dedusting with an ion shower and is suitable for the most difficult dedusting tasks.

■ 4-stage dedusting process

■ high material throughput at max. dedusting degree

■ gentle dedusting

■ special glass construction

■ control stand with cleaning aid

■ 1- or 2-component version

■ air-floating with ion-cleaning
2x ionizer integrated

material throughput up to 70 kg/h*

* depending on material and required degree of dedusting
example based on PMMA/PC

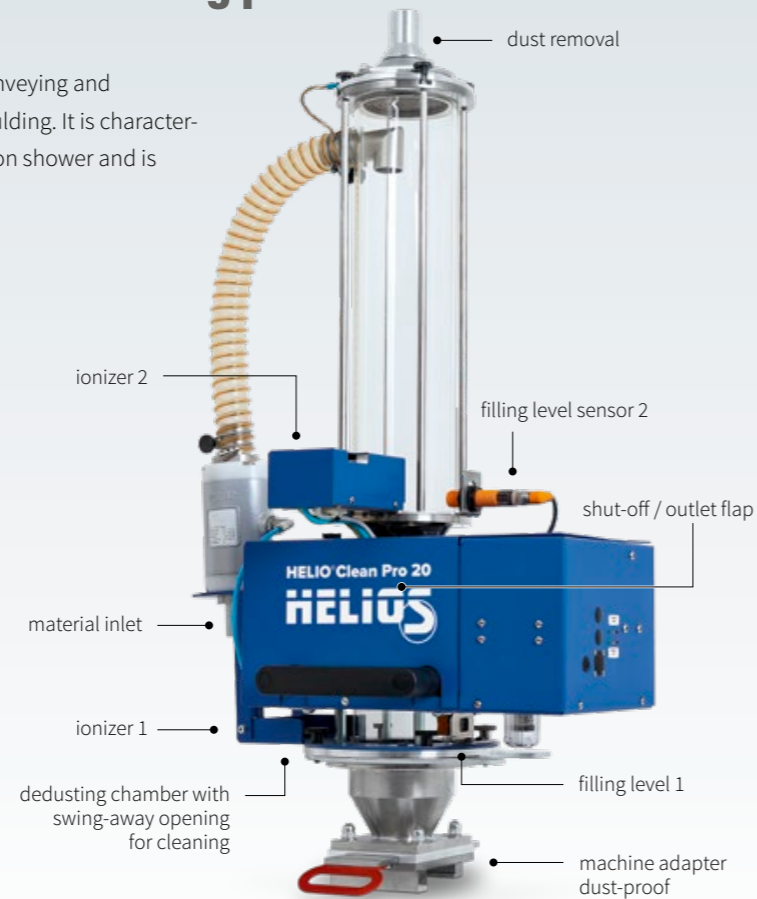

Example: HELIO®Clean Pro 20
1 component

Control stand

- system control
- vacuum generator with dust filter
- dust collection container
- filter cleaning
- cleaning set

Technical data	
Material	special glass, stainless steel, Al nickel-plated
Filling capacity	up to 800 g
Material throughput	50 to 70 kg/h*
Conveying pipe	DN 32
Conveying height	max. 8 m
Electrical connection	~ 100 - 240 V AC, 50/60 Hz
Power consumption	max. 25 W
Pneumatic connection	min. 6 bar, 1/2"
Compressed air quality	max. oil content ≤ 0.01 mg/m ³
Temperature range	0 - 40 °C

Construction

M-version

for mounting on processing machine



Typical applications

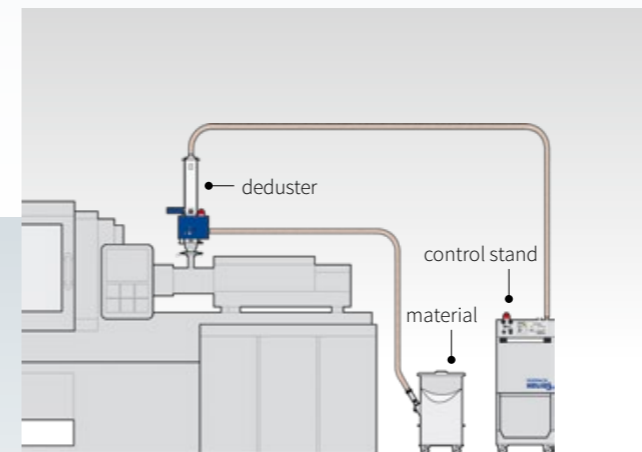

Conveying and dedusting of the material directly on the feeding zone.

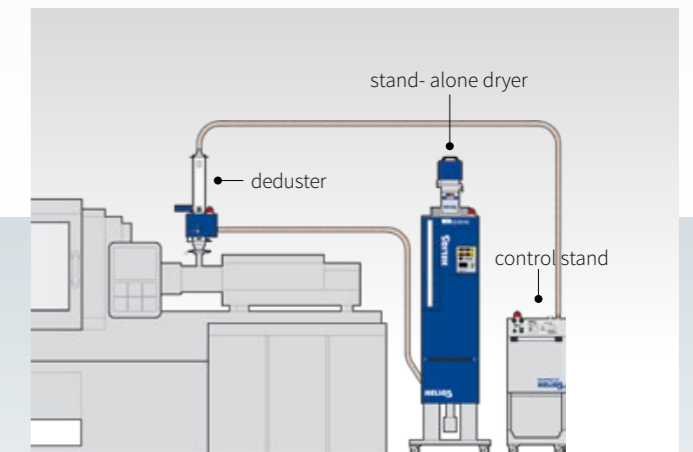

Material drying via stand alone dryer with subsequent conveying and dedusting of the material on the feeding zone.



Conveying hose package

	long	short
suction pipe length	810 mm	380 mm
+ conveying hose (standard)	3 m DN 32	3 m DN 32
+ conveying hose (optional)	5 m DN 32	5 m DN 32



Standard equipment

- M-version for mounting on processing machine
- 1-component version
- control stand with dust collector
- 2 ionizers as standard
- shut-off conveying line
- shut-off / outlet flap
- switchable vacuum cleaner for cleaning the dust collector
- suction pipe and conveyor hose PUR-H 3 m
- dust discharge hose 5 m

Options

- 2-component version (Mix)
- conveying hose PUR-H 5 m
- machine adapter
- intermediate container 2.0 liter

HELIO®Clean Pro system control

Control stand with dust collecting container

Electronic control with microcontroller, programming interface for firmware updates, adjustment via 4 function keys with sub-levels, infinitely variable fine adjustment for conveying and air-floating.

- 5-stage vacuum generator
- dust collecting container
- automatic filter cleaning
- integrated cleaning aid
- system pressure regulator
- quick coupling for control line



Hose bridge

Control stand with telescopic hose bridge for supporting the control pipe and the dust removal hose.

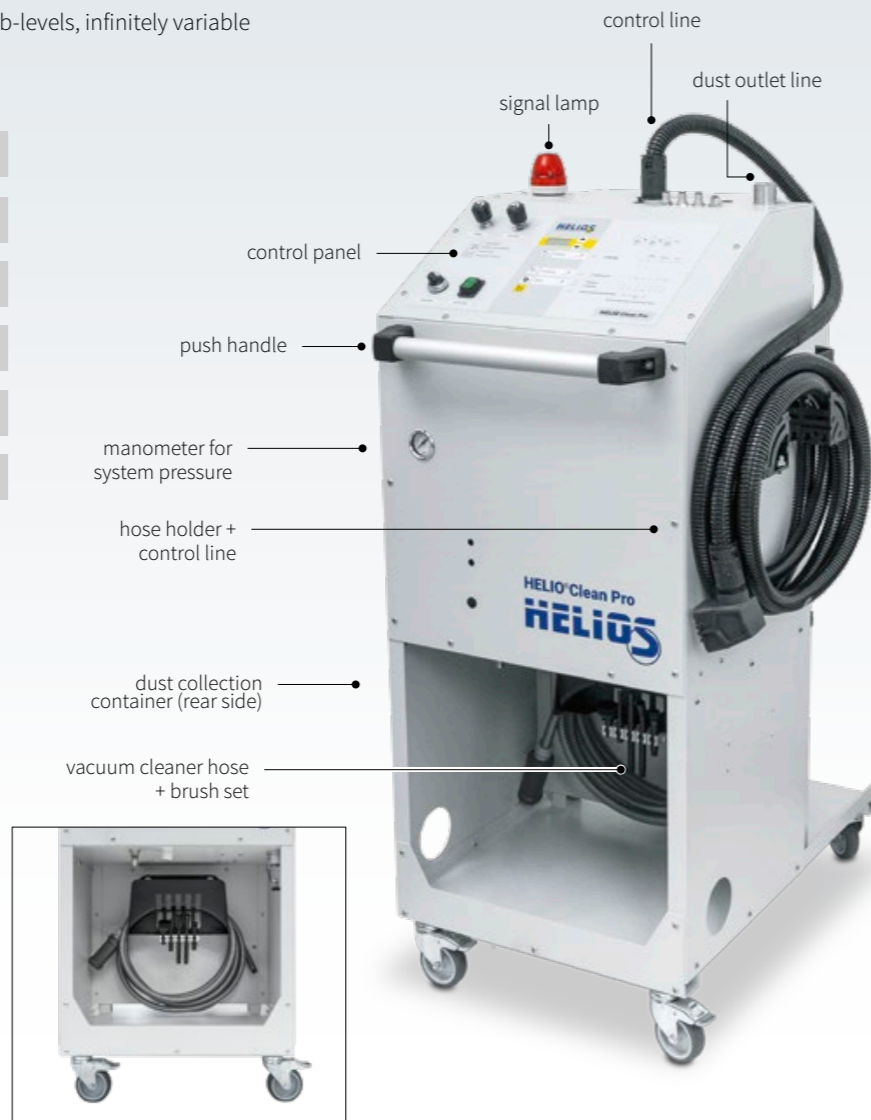

Operation

Extensive setting options

The basic setting and the possible settings for the four functional areas are visible at the control stand. Each function key has several sub-levels which can be called up by pressing the key. Detailed operating instructions allow you to optimize the process steps for each application.



Automatical filter cleaning



Dust collecting container

The dust collection container can be simply pulled out and emptied.



back side

Control line for HELIO®Clean Pro 10

2 coupling plugs with quick locking for energy and signals
Length 5 m between control stand and valve box
Length 0.7 m between valve box and separator

Control line for HELIO®Clean Pro 20

1 coupling plug with quick locking for energy and signals
Length 5 m between control stand and separator

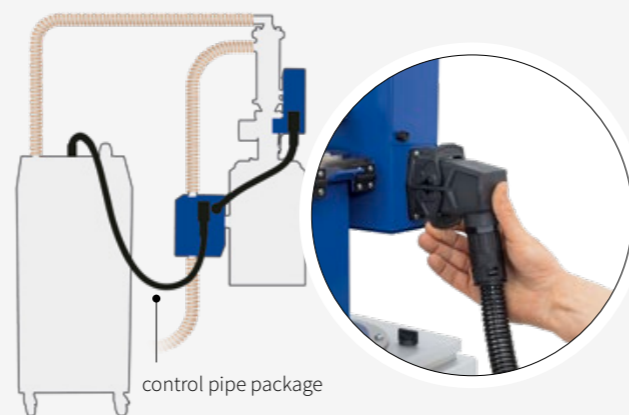

control pipe package

System control with integrated cleaning aid

Easy handling / effortless cleaning

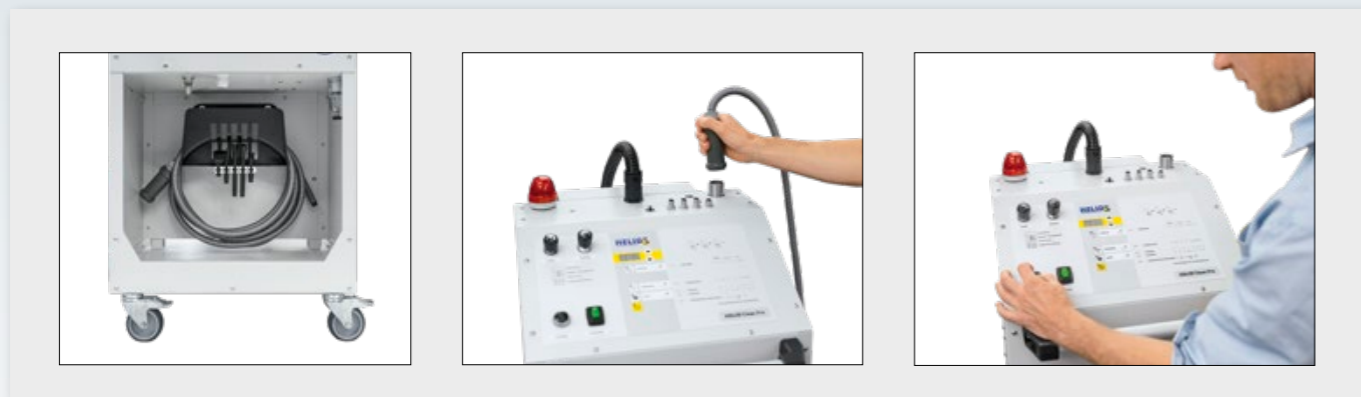

Use as cleaning aid

To clean the dust extractor, the control stand can be used as a classic vacuum cleaner. Instead of the dust discharge hose, the vacuum cleaner hose is plugged on and used together with one of the supplied cleaning attachments.

HELIO®Clean Pro 10

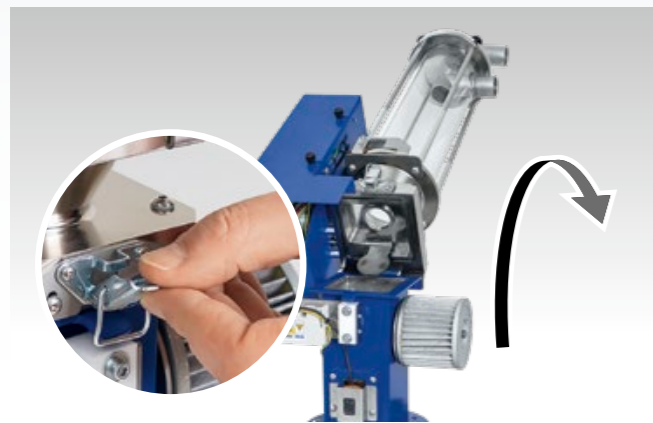

The dedusting chamber can be hinged down

The dedusting chamber can be hinged down for cleaning with just one movement.



HELIO®Clean Pro 20



Dedusting chamber can be swivelled out

Upper part of the deduster can be released and swivelled out in a few simple steps.



HELIO®Clean Pro 10/20



Accessories and options

Conveying hose package



- suction pipe
- conveying hose PUR-H with earthing

	suction pipe long	suction pipe short
suction pipe length	810 mm	380 mm
+ conveying hose (standard)	3 m DN 32	3 m DN 32
+ conveying hose (optional)	5 m DN 32	5 m DN 32

Intermediate container



- 0,5 liter
- 2,0 liter
- 5,0 liter

Machine adapter

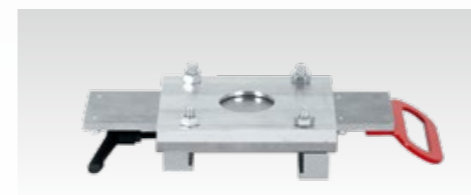

- shut-off valve made of stainless steel
- dustproof version
- L-guide rails made of steel, nickel-plated
- clamping lever for sliding rail

for sliding rail (mm)

70 x 10 80 x 15 80 x 20

Special sizes are available on request.

Mobile dedusting station



Separator connected to control stand. Filling of the dedusted granulate in mobile day container.

HELIO® Clean Pro control stand colour



available in HELIOS blue or light grey

HELIO®Clean 2/3

Accessories and options

Conveying hose package



- suction pipe Venturi
- conveying hose PUR-H with earthing
- compressed air line bundled with hose

	suction pipe long	suction pipe short
suction pipe length	810 mm	380 mm
+ conveying hose (standard)	3 m DN 32	3 m DN 32
+ conveying hose (optional)	5 m DN 32	5 m DN 32

Dust removal



The removed dust is separated in the dust collection container. An integrated exhaust air filter ensures dust-free ambient air.

	dust collecting container
dust collecting container volume (standard)	5,5 liter
volume expansion (optional) + 11 liter	16,5 liter
+ dust removal hose	5 m DN 50

Machine adapter

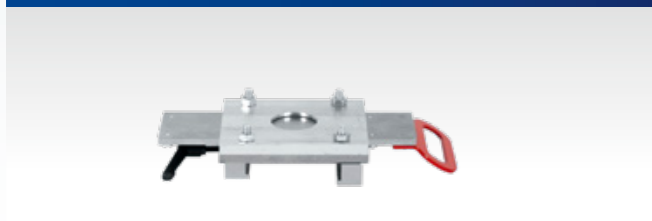

- shut-off valve made of stainless steel
- dustproof version
- L-shaped guide rails made of steel, nickel-plated
- clamping lever for sliding rail

for sliding rails [mm]

70 x 10 80 x 15 80 x 20

Special sizes available on request.

Intermediate container



- 0,5 liter
- 2,0 liter
- 5,0 liter

JETBOXX® dryer with option CE



- WINneo® or WINsystem®
- Option CE corresponds to HELIO®Clean 2 1-component

JETBOXX® dryer with option ME



- WINsystem®
- Option ME corresponds to HELIO®Clean 2 Mix 2-components

HELIO®Clean type overview

We will be happy to help you to select the right device for your requirements. You are welcome to send us a material sample of the granulate or regrind material to be dedusted and we will carry out tests for you in our technical centre. In case of a positive result, we will make a recommendation for the ideal device and you can test the deduster at your site.



	HELIO®Clean 2	HELIO®Clean 3	HELIO®Clean Pro 10	HELIO®Clean Pro 20
material throughput*	max. 25 kg/h	max. 25 kg/h	max. 35 kg/h	max. 50 - 70 kg/h
filling quantity	up to 200 g	up to 300 g	up to 400 g	up to 800 g
process	whirling up by compressed air jet from above	air-floating with whirling up by ionized compressed air from below	air-floating with ionized air by circulating in the fountain	
ionizer	no ionization possible	1 ionizer standard	2 ionizers standard	
dust removal	separate dust collection container		dust collection container integrated in control stand	
control	HELIO®Clean 2 or JETBOXX® control	HELIO®Clean 3 control	HELIO®Clean Pro control stand	
place of action	suitable for mounting on processing machine or drying container	suitable for mounting on processing machine or drying container	suitable for mounting on processing machine or drying container	particularly suitable for mounting on processing machine
features	<ul style="list-style-type: none"> ■ compact or split version ■ 1- or 2-components version ■ separate dust collection container ■ Venturi suction lances 	<ul style="list-style-type: none"> ■ compact or split version ■ 1- or 2-components version ■ separate dust collection container ■ intermediate container for dedusted material ■ cleaning of dust collection chamber with ion flushing ■ Venturi suction lances 	<ul style="list-style-type: none"> ■ separate control combined with 3-step vacuum generator and dust collection container ■ 1- or 2-components version ■ lockable conveying pipe(s) ■ shut-off / outlet flap ■ hinged dedusting chamber for cleaning ■ conveying speed and air-floating power steplessly adjustable 	<ul style="list-style-type: none"> ■ separate control combined with 3-step vacuum generator and dust collection container ■ 1- or 2-components version ■ lockable conveying pipe(s) ■ shut-off / outlet flap ■ swing-out dedusting chamber for cleaning ■ conveying speed and air-floating power steplessly adjustable

* depending on material and required degree of dedusting example based on PMMA/PC

JETBOXX® Drying system

Dry-air dryers for plastic granulate



Top-mounted dryers



Mobile dryers



Variable dryer station



Dryer station

OKTOMAT® Emptying system

Discharging stations for Octabin and BigBag



OKTOMAT® SOS



OKTOMAT® SOS Classic



OKTOMAT® SOS INOX



OKTOMAT® ECO



OKTOMAT® ECO Classic

HELIO®Clean Dedusting system

Dedusters for plastic granulate/regrind



HELIO®Clean 2



HELIO®Clean 3



HELIO®Clean Pro 10



HELIO®Clean Pro 20

Consulting and quoting

The first step for a successful and long-lasting cooperation always starts with the personal contact to the customer. Our experienced sales representatives will be happy to advise you directly on site about the latest technical developments from HELIOS and their possible applications.

We carry out significant material tests in our in-house technology center and provide you with a detailed test protocol. We will show you the advantages of our products for the expansion or modernization of your machinery and will immediately prepare an individual quotation for you.

Short delivery times of 4 - 8 weeks are standard at HELIOS.

After Sales Service

Our service department will be at your disposal during the entire period of use with competent advice on all pending questions or carry out repairs, maintenance and calibrations on request even on site.

Commissioning

Knowing your equipment and machines inside out is the only way to ensure optimal and efficient use. For this reason, all HELIOS products have detailed installation and operating instructions to make the proper use of our equipment as easy as possible and therefore ensure safe and efficient operation. HELIO®Clean dedusters are largely prepared for „Plug&Play“.

Spare parts delivery within 48h

A missing spare part can lead to a complete shutdown of the entire plant and therefore cause considerable financial damage.

We keep the majority of the necessary components in our spare parts warehouse, which we can provide within the shortest possible time.

Test equipment

Test equipment is available for almost all HELIOS products on the basis of a rental contract.

used worldwide

More than 1000 dedusting system units have been delivered by HELIOS



Training

Of course we also offer specific training directly on site or in our technical center.

During the training, your employees will be supported by our competent service technicians and learn the concrete handling of the technology used.

The acquired knowledge about our products reduces operating errors significantly and avoids possible failures in your production.

Take advantage of our training courses and benefit from additional advantages:

- Increasing the qualification of your employees
- Effective use of machines and equipment
- No downtimes due to operating errors
- Follow-up training after approx. 6 months





Your perfect partner for material handling



JETBOXX®

Drying system

Dry-air dryers for plastic granulate



OKTOMAT®

Emptying system

Discharging stations for Octabin and BigBag



HELIO® Clean

Dedusting system

Dedusters for plastic granulate/regrind

HELIOS GmbH

Gerätebau für Kunststofftechnik

Hechtseestraße 8
83022 Rosenheim
GERMANY

Tel +49 (0)8031 35418-0
Fax +49 (0)8031 35418-60

info@helios-systems.com
www.helios-systems.com

